

STEARNS CERAMIC 8 PERMANENT MAGNETIC DRUM SEPARATORS

These separators provide automatic and continuous removal of tramp iron in process industries, including: ceramics, chemicals, foods, grain, minerals, plastics, rubber and tobacco. The **Ceramic 8 Separator** offers positive protection and low cost, lifetime dependability. Inspired by the design advantages of the **Ceramic 8**, Stearns engineers pioneered a new era in the development of efficient magnetic separation equipment. In the **Ceramic 8**, the exclusive ceramic magnet assembly produces a uniform magnetic field...to **40% more powerful** than in ordinary permanent magnet systems.



IDEAL FOR SPOUT SYSTEMS!

Here is a unit that is ideal for process industries wherever granular or pulverized materials are conveyed in closed chutes and spouts. The **Ceramic 8 Drum Separator** continuously and automatically removes tramp iron, carries it out of the material flow and returns a clean product to the production process.

WORKING PRINCIPLE IS SIMPLE

In operation, the **Ceramic 8 Drum Separator** consists of a revolving non-magnetic cylinder inside a steel welded housing. Material is fed onto the cylinder at the top and is carried over the stationary magnet assembly (see illustration). The deep uniform field attracts and holds tramp iron particles beyond the discharge of the clean, non-magnetic product. Tramp iron is released into a separate discharge as it passes out of the magnetic field.

IMPORTANT FEATURES...deliver superior performance

There are numerous important features built into the Stearns **Ceramic 8 Drum Separator** and all are designed to provide superior performance and service, including:

- **Reliable Holding Power at drum surface assures positive attraction and transportation of tramp iron particles**
- **Factory Sealed Bearings**
- **Optional Spouting Arrangements**
- **Direct Gear-Motor Drive eliminates belts, chains or sprockets**
- **Flanged Housing mounts easily in any spouting system**
- **Totally Enclosed with dust protective housing**
- **Ceramic 8 Magnet Assembly is lightweight and provides resistance to demagnetization**
- **Rare Earth Magnetic Field Models are available on request**

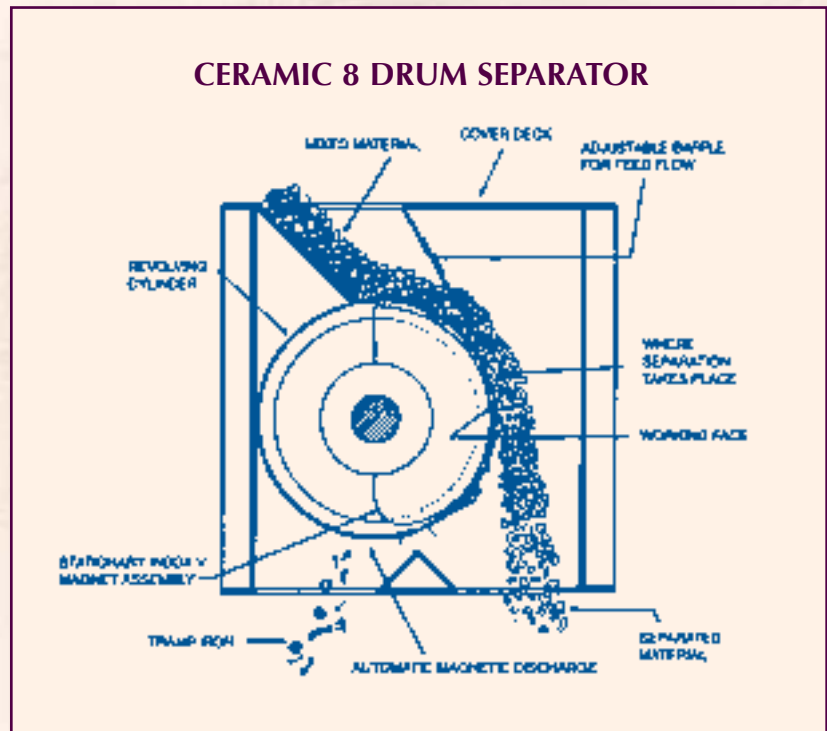

STEARNS CERAMIC 8 PERMANENT MAGNETIC DRUM SEPARATORS

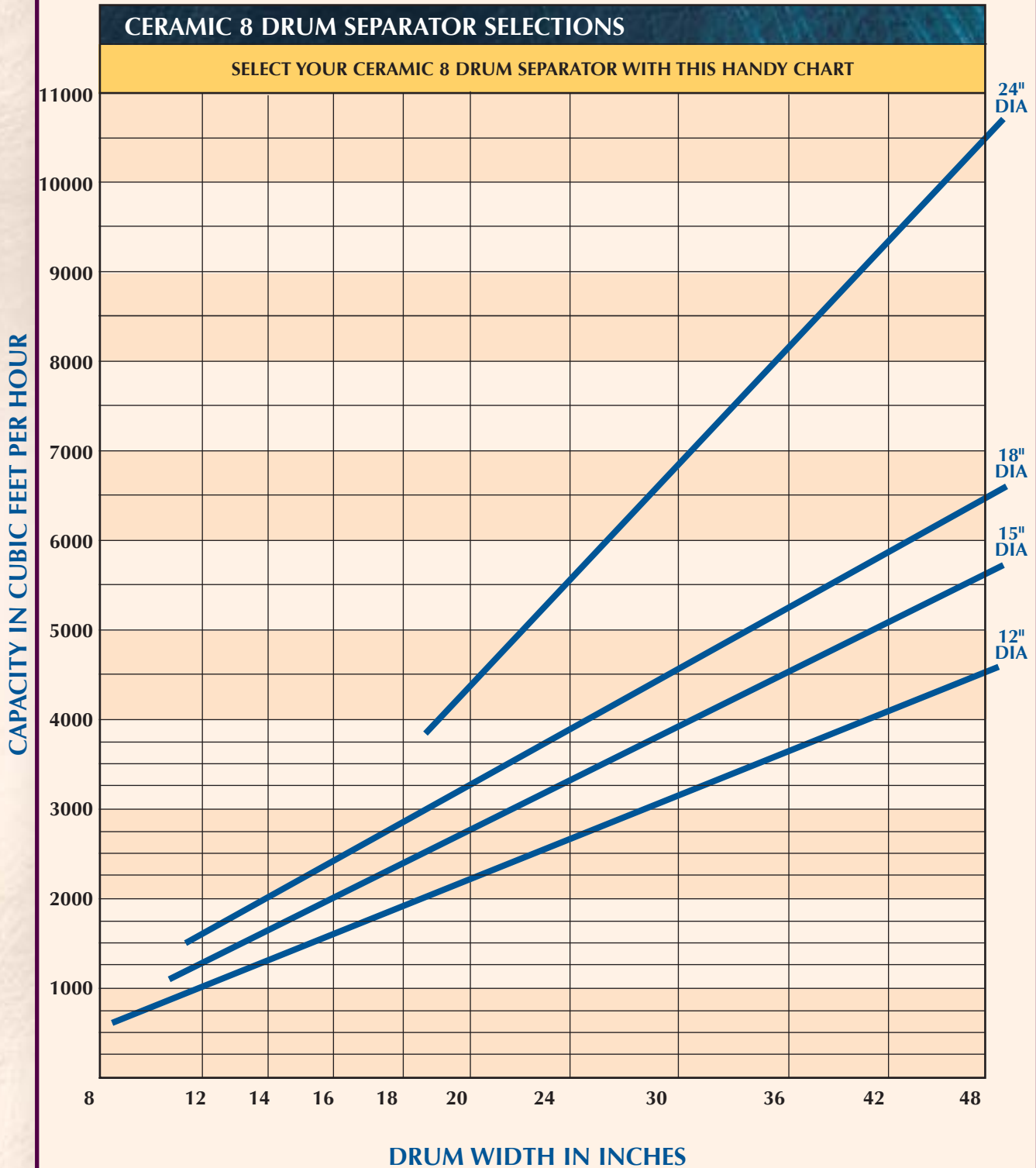

THIS IS A TYPICAL CHART USED FOR GRAINS. CONSULT FACTORY FOR SEPARATOR SIZE ON DIFFERENT MATERIALS.

SERIES 510

TECHNICAL SPECIFICATIONS AND DIMENSIONS (INCHES)

A	B	C*	D*	E*	F*	G*	J	L*	M	P*	Q	Mech. H.P. Req'd	Approx. R.P.M. Req'd	Ship.Wt. (lbs)
12-INCH DIAMETER														
8	7	1-15/16	1-9/16	13-1/8	7-1/4	2-1/4	7-1/4	3-1/4	1	1-1/8	15-5/8	1/4	58	120
12	11	↓	↓	↓	↓	↓	9-1/4	↓	↓	↓	19-5/8	1/4	↓	135
14	13	↓	↓	↓	↓	↓	10-1/4	↓	↓	↓	21-5/8	1/4	↓	150
16	15	↓	↓	↓	↓	↓	11-1/4	↓	↓	↓	23-5/8	1/4	↓	175
18	17	↓	↓	↓	↓	↓	12-1/4	↓	↓	↓	25-5/8	1/3	↓	185
20	19	↓	↓	↓	↓	↓	13-1/4	↓	↓	↓	27-5/8	1/3	↓	195
24	23	↓	↓	↓	↓	↓	15-1/4	↓	↓	↓	31-5/8	1/3	↓	215
30	29	↓	↓	↓	↓	↓	18-1/4	↓	↓	↓	37-5/8	1/3	↓	255
36	35	↓	↓	↓	↓	↓	21-1/4	↓	↓	↓	43-5/8	1/2	↓	285
42	41	↓	↓	↓	↓	↓	24-1/4	↓	↓	↓	49-5/8	1/2	↓	335
48	47	↓	↓	↓	↓	↓	27-1/4	↓	↓	↓	55-5/8	1/2	↓	350
15-INCH DIAMETER														
12	11	1-15/16	1-9/16	17	9-1/4	2-1/4	9-1/4	3-1/4	1	1-5/8	20-1/8	1/4	58	260
14	13	↓	↓	↓	↓	↓	10-1/4	↓	↓	↓	22-1/8	1/4	↓	320
16	15	↓	↓	↓	↓	↓	11-1/4	↓	↓	↓	24-1/8	1/3	↓	335
18	17	↓	↓	↓	↓	↓	12-1/4	↓	↓	↓	26-1/8	1/3	↓	350
20	19	↓	↓	↓	↓	↓	13-1/4	↓	↓	↓	28-1/8	1/3	↓	370
24	23	↓	↓	↓	↓	↓	15-1/4	↓	↓	↓	32-1/8	1/2	↓	435
30	29	↓	↓	↓	↓	↓	18-1/4	↓	↓	↓	38-1/8	1/2	↓	480
36	35	↓	↓	↓	↓	↓	21-1/4	↓	↓	↓	44-1/8	1/2	↓	550
42	41	↓	↓	↓	↓	↓	24-1/4	↓	1-1/4	↓	50-1/8	3/4	↓	610
48	47	↓	↓	↓	↓	↓	27-1/4	↓	1-1/4	↓	56-1/8	3/4	↓	685
18-INCH DIAMETER														
12	11	2-3/16	1-3/16	21	12-3/4	3-1/2	9-5/8	3-1/2	1	1-5/8	20-3/4	1/3	43	360
14	13	↓	↓	↓	↓	↓	10-5/8	↓	↓	↓	22-3/4	1/3	↓	410
16	15	↓	↓	↓	↓	↓	11-5/8	↓	↓	↓	24-3/4	1/3	↓	455
18	17	↓	↓	↓	↓	↓	12-5/8	↓	↓	↓	26-3/4	1/2	↓	490
20	19	↓	↓	↓	↓	↓	13-5/8	↓	↓	↓	28-3/4	1/2	↓	530
24	23	↓	↓	↓	↓	↓	15-5/8	↓	↓	↓	32-3/4	1/2	↓	590
30	29	↓	↓	↓	↓	↓	18-5/8	↓	1-1/4	↓	38-3/4	3/4	↓	725
36	35	↓	↓	↓	↓	↓	21-5/8	↓	1-1/4	↓	44-3/4	3/4	↓	755
42	41	↓	↓	↓	↓	↓	24-5/8	↓	1-1/4	↓	50-3/4	1	↓	1075
48	47	↓	↓	↓	↓	↓	27-5/8	↓	1-1/4	↓	56-3/4	1	↓	1330
24-INCH DIAMETER														
18	17	2-7/16	2-1/16	27-1/4	17-1/8	4-1/2	13	4	1-1/4	1-3/4	27-3/4	3/4	43	885
20	19	↓	↓	↓	↓	↓	14	↓	1-1/4	↓	29-3/4	3/4	↓	930
24	23	↓	↓	↓	↓	↓	16	↓	1-1/4	↓	33-3/4	3/4	↓	1050
30	29	↓	↓	↓	↓	↓	19	↓	1-1/2	↓	39-3/4	1	↓	1400
36	35	↓	↓	↓	↓	↓	22	↓	1-1/2	↓	45-3/4	1	↓	1600
42	41	↓	↓	↓	↓	↓	25	↓	1-1/2	↓	51-3/4	1-1/2	↓	1740
48	47	↓	↓	↓	↓	↓	28	↓	1-1/2	↓	57-3/4	1-1/2	↓	2130

* Where only one dimension appears in the column, this dimension is the same for all separators in group.

Stearns Series 510 Ceramic 8 Drum (Only) is supplied without housing. Can be installed directly in spout system or equipped with special enclosure to meet your needs.

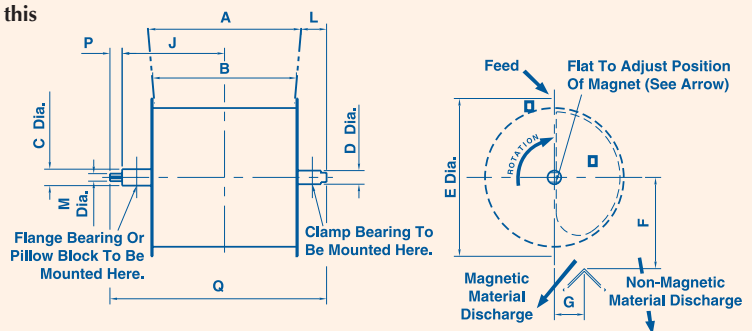
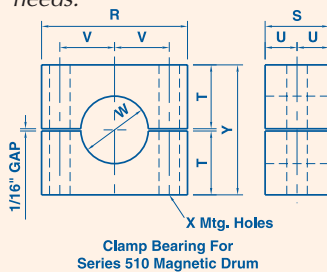

SIZE DRUM DIA.	R	S	T	V	U	W	X	Y	WEIGHT (lbs)
12	3-1/4	1-1/2	1-1/2	1-3/8	3/4	1-19/32	9/16	3-1/16	3.50
15	3-1/4	1-1/2	1-1/2	1-3/8	3/4	1-19/32	9/16	3-1/16	3.50
18	4	1-3/4	1-1/4	1-1/2	7/8	1-27/32	9/16	3-9/16	5.25
24	4-1/4	2	2	1-3/4	1	2-3/32	11/16	4-1/16	8.00

SERIES 520

TECHNICAL SPECIFICATIONS AND DIMENSIONS (INCHES)

A	B*	C*	D*	E	F	G	H*	J	L*	M*	N*	P*	Q	R	Flange Holes	Mech. H.P. Req'd	Approx. R.P.M. Req'd	Ship. Wt. (lbs)
12-INCH DIAMETER																		
8	8-1/2	7	7	11-3/16	21-1/2	11-1/2	22	7-1/4	3-1/4	8-1/2	9-1/2	1-1/8	15-5/8	1	11/32	1/4	58	170
12	↓	↓	↓	11-3/16	↓	15-1/2	↓	9-1/4	↓	↓	↓	↓	19-5/8	↓	↓	1/4	↓	195
14	↓	↓	↓	11-3/16	↓	17-1/2	↓	10-1/4	↓	↓	↓	↓	21-5/8	↓	↓	1/4	↓	215
16	↓	↓	↓	11-3/16	↓	19-1/2	↓	11-1/4	↓	↓	↓	↓	23-5/8	↓	↓	1/4	↓	245
18	↓	↓	↓	11-3/16	↓	21-1/2	↓	12-1/4	↓	↓	↓	↓	25-5/8	↓	↓	1/3	↓	260
20	↓	↓	↓	11-3/16	↓	23-1/2	↓	13-1/4	↓	↓	↓	↓	27-5/8	↓	↓	1/3	↓	275
24	↓	↓	↓	11-3/16	↓	27-1/2	↓	15-1/4	↓	↓	↓	↓	31-5/8	↓	↓	1/3	↓	305
30	↓	↓	↓	11-3/16	↓	33-1/2	↓	18-1/4	↓	↓	↓	↓	37-5/8	↓	↓	1/3	↓	360
36	↓	↓	↓	12-3/16	↓	39-1/2	↓	21-1/4	↓	↓	↓	↓	43-5/8	↓	↓	1/2	↓	405
42	↓	↓	↓	12-3/16	↓	45-1/2	↓	24-1/4	↓	↓	↓	↓	49-5/8	↓	↓	1/2	↓	470
48	↓	↓	↓	12-3/16	↓	51-1/2	↓	27-1/4	↓	↓	↓	↓	55-5/8	↓	↓	1/2	↓	500
15-INCH DIAMETER																		
12	10-1/2	8-3/4	8-3/4	11-3/16	28	17	27-1/2	9-1/4	3-1/4	11-1/4	12-1/4	1-5/8	20-1/8	1	11/32	1/4	58	315
14	↓	↓	↓	11-3/16	↓	19-1/2	↓	10-1/4	↓	↓	↓	↓	22-1/8	1	↓	1/4	↓	380
16	↓	↓	↓	11-3/16	↓	21-1/2	↓	11-1/4	↓	↓	↓	↓	24-1/8	1	↓	1/3	↓	400
18	↓	↓	↓	11-3/16	↓	23-1/2	↓	12-1/4	↓	↓	↓	↓	26-1/8	1	↓	1/3	↓	420
20	↓	↓	↓	11-3/16	↓	25	↓	13-1/4	↓	↓	↓	↓	28-1/8	1	↓	1/3	↓	450
24	↓	↓	↓	12-3/16	↓	29	↓	15-1/4	↓	↓	↓	↓	32-1/8	1	↓	1/2	↓	530
30	↓	↓	↓	12-3/16	↓	35	↓	18-1/4	↓	↓	↓	↓	38-1/8	1	↓	1/2	↓	600
36	↓	↓	↓	12-3/16	↓	41	↓	21-1/4	↓	↓	↓	↓	44-1/8	1	↓	1/2	↓	670
42	↓	↓	↓	12-3/16	↓	47	↓	24-1/4	↓	↓	↓	↓	50-1/8	1-1/4	↓	3/4	↓	750
48	↓	↓	↓	12-3/16	↓	53	↓	27	↓	↓	↓	↓	56-1/8	1-1/4	↓	3/4	↓	830
18-INCH DIAMETER																		
12	14	12	12	11-3/16	35	17	35	9-1/8	3-1/2	14	16	1-5/8	20-3/4	1	13/32	1/3	43	425
14	↓	↓	↓	11-3/16	↓	19	↓	10-5/8	↓	↓	↓	↓	22-3/4	1	↓	1/3	↓	470
16	↓	↓	↓	11-3/16	↓	21	↓	11-5/8	↓	↓	↓	↓	24-3/4	1	↓	1/3	↓	510
18	↓	↓	↓	12-3/16	↓	23	↓	12-5/8	↓	↓	↓	↓	26-3/4	1	↓	1/2	↓	550
20	↓	↓	↓	12-3/16	↓	25	↓	13-5/8	↓	↓	↓	↓	28-3/4	1	↓	1/2	↓	595
24	↓	↓	↓	12-3/16	↓	29	↓	15-5/8	↓	↓	↓	↓	32-3/4	1	↓	1/2	↓	660
30	↓	↓	↓	12-3/16	↓	35	↓	18-5/8	↓	↓	↓	↓	38-3/4	1-1/4	↓	3/4	↓	800
36	↓	↓	↓	12-3/16	↓	41	↓	21-5/8	↓	↓	↓	↓	44-3/4	1-1/4	↓	3/4	↓	940
42	↓	↓	↓	12-3/16	↓	47	↓	24-5/8	↓	↓	↓	↓	50-3/4	1-1/4	↓	1	↓	1175
48	↓	↓	↓	12-3/16	↓	53	↓	27-5/8	↓	↓	↓	↓	56-3/4	1-1/4	↓	1	↓	1445
24-INCH DIAMETER																		
18	19-1/2	17	17	12-3/16	48	24	48	13	4	19-1/2	21-1/2	1-3/4	27-3/4	1-1/4	9/16	3/4	43	945
20	↓	↓	↓	12-3/16	↓	26	↓	14	↓	↓	↓	↓	29-3/4	1-1/4	↓	3/4	↓	1000
24	↓	↓	↓	12-3/16	↓	30	↓	16	↓	↓	↓	↓	33-3/4	1-1/4	↓	3/4	↓	1140
30	↓	↓	↓	13-3/8	↓	36	↓	19	↓	↓	↓	↓	39-3/4	1-1/2	↓	1	↓	1520
36	↓	↓	↓	13-3/8	↓	42	↓	22	↓	↓	↓	↓	45-3/4	1-1/2	↓	1	↓	1750
42	↓	↓	↓	14-5/16	↓	48	↓	25	↓	↓	↓	↓	51-3/4	1-1/2	↓	1-1/2	↓	1920
48	↓	↓	↓	14-5/16	↓	54	↓	28	↓	↓	↓	↓	57-3/4	1-1/2	↓	1-1/2	↓	2340

* Where only one dimension appears in the column, this dimension is the same for all separators in group.

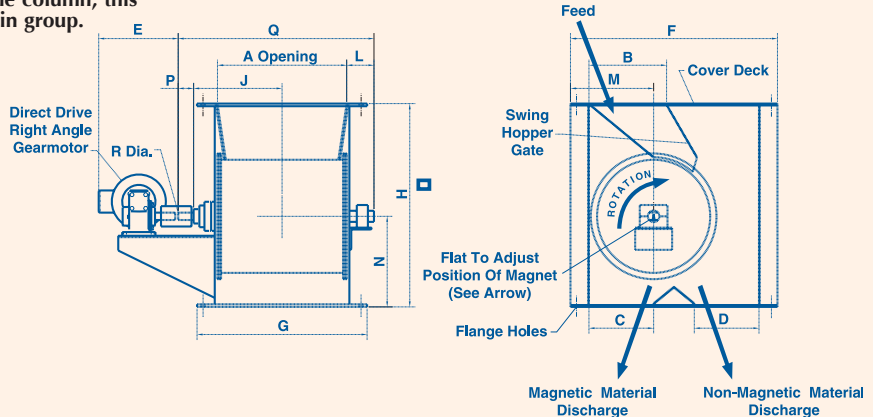

Stearns Series 520 Ceramic 8 Drum Separator, for vertical spouting systems, provides openings for discharge of tramp iron and clean product in an integral housing

STEARNS "WPD" WET MAGNETIC DRUM SEPARATORS

APPLICATION

Wet drum separators are used in magnetic media recovery, purification of solids carried in liquid suspension and in iron ore concentration. Stearns has developed a specific line of separators for handling slurries developed in heavy media plants. These heavy media plants require:

1. Magnetic separators which recover magnetics contained in feed slurries as efficiently as possible, to reduce the per ton/media consumption of treated product to a minimum.
2. Recovery of magnetic solids in as clean a magnetic concentrate as possible, to keep the separating bath at a low viscosity, and to eliminate a misplaced product.
3. A high gravity magnetic discharge to eliminate, in many instances, the need for a densifier. A high gravity concentrate simplifies plant operation.
4. Trouble-free operation with minimum down time, minimum operator attention and minimum cost.



Available Features

- 30", 36" and 48" Diameters
- Drum Widths Up to 120"
- Con-Current or Counter-current Models
- Standard or High Gauss Magnet Assemblies
- Single or Double Drum Units
- Stainless Steel Wear Covers
- Direct Drive
- High Volume Models
- Self-Leveling Design

FACTORS INFLUENCING SEPARATOR SELECTIONS

Five basic factors influence proper selection of a magnetic separator in terms of drum diameter, magnetic width, and type of wet drum separator for use in a specific application. These are:

1. Volume of Slurry to be Handled
2. Percent of Solids in Rinse Slurry
3. Percent of Magnetics in Feed Solids of the Rinse Slurry
4. Required Magnetics Recovery Efficiency
5. Cleanliness Required in the Magnetic Concentrate Products



One of the features of Stearns magnetic separator is its ability to handle widely fluctuating fluids. Thus, applications can be found lying outside the service limits indicated. However, the limits outlined below are basic guide lines which assure efficient magnetic separator performance. These guide lines will indicate changes that can be made in existing plants to improve media recovery efficiency. Each factor must be considered jointly for each individual application.

FEED VOLUME*...Feed volume should not exceed 75 gpm/ft. of magnet width on a 30 in. diameter single drum separator. If feed volumes up to 90 gpm/ft. must be handled, a double-drum separator (rougher-scavenger model), in which the primary drum tailing and overflow product are sent to the secondary drum, should be applied. Efficient magnetic recovery cannot be expected at rates beyond 90 gpm/ft.

PERCENT SOLIDS IN FEED*...The ratio of magnetic solids to non-magnetic solids cannot be efficiently isolated from total percent solids in evaluating magnetic recovery. As a general rule, the limiting recommended feed solids in a media recovery circuit is 50%. Variations of the ratio of magnetics to non-magnetics solids within this solids range can produce many potential feed slurries. The recommended maximum percent of solids for a single drum separator is 15% for con-current separators, 20% solids maximum can be tolerated without losing magnetic efficiency. Beyond 20% solids double-drum separators (rougher-scavenger) are recommended. In cases where the feed slurry goes above 30% solids, which sometimes occurs when a cyclone is being used to thicken a dilute rinse slurry product, sufficient water should be added in the feed box of the primary separator to bring it down to the 30% solids figure.

% OF MAGNETICS IN FEED SOLIDS OF THE RINSE SLURRY*...The ratio to non-magnetic solids will influence the purity of the concentrated obtained. The non-magnetic content tends to deter magnetic cleaning when the non-magnetic to magnetic ratio exceeds 40% by weight. If the feed pulp is sufficiently diluted (below 20% solids), purity of the magnetic concentrate will not be seriously affected at the 40% figure. When the total solids figure exceeds 20%, and when the non-magnetic to magnetic solids ratio exceeds 40%, it is difficult to obtain a high purity concentrate. This lopsided condition usually occurs in plants using reclaimed water and is alleviated by pulp dilution; or by running the media through the magnetic separator while the plant is not running, thus further rejecting non-magnetics. A primary limitation in magnetic separator selection, influenced by percent magnetics in the solids, is the magnetic discharge loading on the magnetic separator. Single-drum 30 in. diameter con-current separators should be limited to 3 tph of magnetic discharge per ft. of magnet width. These magnetic discharge limits are suggested in line with good magnetic cleaning at good magnetic recovery efficiencies. Counter-current separators can retain magnetic recovery at a sacrifice in magnetic cleaning at a discharge rate 30% higher than the above figures. A double-drum magnetic separator will permit the magnetic discharge rate to increase to as much as 30% above the indicated single-drum rate. Optimum magnetic cleaning and recovery at this increased rate can be obtained with a double-drum separator with con-current primary drum and a counter-current secondary drum as indicated on Page 26 in Figure #4. The counter-current separator is selected when feed characteristics are variable as to tonnage of magnetic solids and feed volumes. Efficient washing of the drum must be provided at the magnetic discharge point to prevent carry over of the magnetics on the drum.

DOUBLE DRUM TYPE WPD SEPARATORS...Double Drum separators are available in two basic types, depending on tank configuration use: 1. Double con-current tank arrangement shown on Page 26 in Figure #3. 2. Con-current primary with counter-current secondary shown on Page 26 in Figure #4. Double drum separators will either: Give a higher magnetic recovery as compared to single drum units when operated at recommended 75 gpm/ft. 30" diameter or 95 gpm/ft. for 36" diameter volume; or will permit higher feed volumes while obtaining the same recovery as can be reached at lower rates on single drum separators.

* NOTE: Add 20% to the above volume on magnetic discharge rate for 36" diameter models.

STEARNS "WPD" WET MAGNETIC DRUM SEPARATORS

CON-CURRENT SINGLE DRUM TYPE WPD

The con-current tank arrangement is shown in **Figure 1**. This separator is probably the most commonly used type in heavy media today. It gives:

1. Minimum wear on the cylinder, since it introduces the feed slurry in the same direction as the drum is traveling.
2. Maximum cleaning of magnetic solids since all recovered magnetics must traverse the full magnet arc and be subjected to numerous changes in magnet polarity.
3. Material passing wash spray is automatically returned to feed point, possibly of magnetic loss reduced.
4. Highest magnetic solids discharge since it produces best squeezing action at magnetic discharge point and can be operated with a minimum wash spray or with a drum wiper, if necessary.

COUNTER-CURRENT SINGLE DRUM TYPE WPD

The counter-current tank arrangement is shown in **Figure 2**. The counter-current separator's advantages include:

1. Maximum Magnetic Recovery, since the magnetics are recovered and transported a short distance into the magnetic discharge chute. Magnetics missed in the initial pick-up are scavenged out by the remaining poles of the magnet assembly. However, the short recovery zone does reduce the cleanliness of the magnetic concentrate.
2. Heavy Magnetic Loads can be handled without serious reduction of high magnetic recovery, due to the short transportation and scavenging features.
3. Less susceptibility to loss of magnetic efficiency at high feed volumes. Feeds as high as 80 gpm/ft. can be handled efficiently on this counter-current separator.
4. Magnetic discharge on feed side of separator. This sometimes makes plant layout easier.

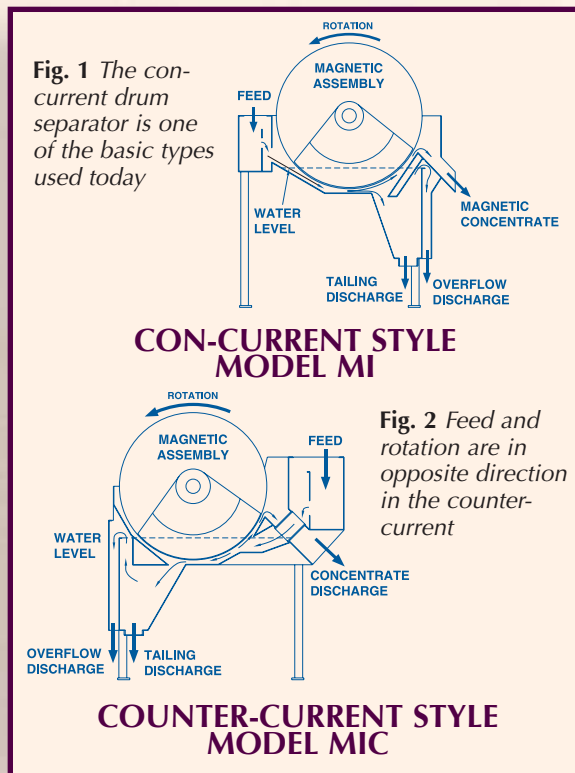

OPTIONAL CONFIGURATIONS OF STEARNS WET MAGNETIC SEPARATORS

Fig. 3 Principles of operation of the double drum con-current wet type separator for magnetic media

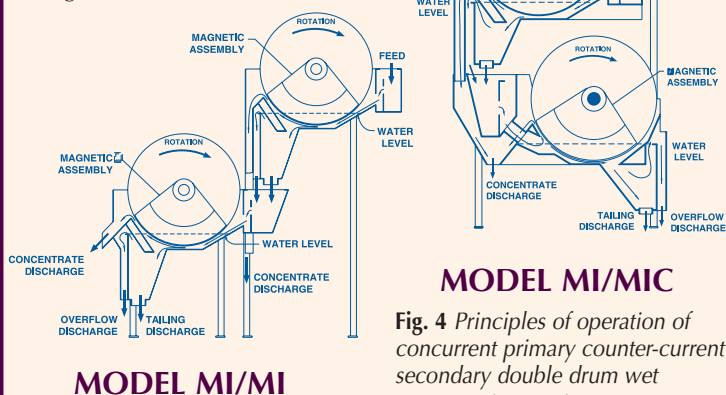

Fig. 4 Principles of operation of concurrent primary counter-current secondary double drum wet permanent separator

STEARNS HIGH VOLUME WET PERMANENT MAGNETIC DRUM SEPARATOR

Stearns' "HV"- High Volume, Wet Permanent Magnetic Separator is designed to handle the demands of increased production rates without adding additional drums to your circuit. The drum utilizes a wider arc magnet to increase retention time for maximum magnetic recovery. The interpole magnet arrangement allows for numerous polarity changes to improve the cleaning of recovered magnetics.

This high volume separator provides you with these features:

- Increased Capacity
- Maximum Magnetic Recovery
- Heavy-Duty Stainless Steel Construction on tank and feed box
- Low Maintenance