

STEARNS MAGNETIC TYPE "LD" DRUMS

Our Magnetic LD Drums are the answer for your heavy industrial applications, including:

- Scrap Shredding
- Slag Reclamation
- Tramp Iron Removal
- Ore Cobbing

Stearns' **Patented Coil Design** develops deep magnetic field with minimum DC power cost. Our electro-magnet drum opens the way to new efficiency in handling large volumes of large size material encountered in today's scrap processing and mineral concentration applications. Our patented coil construction produces a concentrated deep magnetic field to maximize ferrous recovery.

The drum consists of an electro-magnet assembly mounted inside an outer rotating drum assembly. The magnet assembly position, although stationary during operation, may be adjusted within certain limits to meet varying feed arrangements. These versatile products offer you:



Exceptional Construction Features

- Superior Deep Field Design
- Heavy Duty Manganese Steel Cylinders with Knock-Offs
- Rugged Weather Proof Construction
- Radial or Alternating Pole Designs

Available Options

- 6"-8" High Side Shields Bolted to the Drum Heads
- 2 Piece, Heavy Duty Split-Wear Covers
- Your Choice of Knock-Off Patterns
- Permanent Magnet Designs

STEARNS MAGNETIC AXIAL POLE DRUMS

Our Electro-Magnetic Alternating Pole LDA Drum Separators offers the industry a perfect complement to the well-established Stearns **Radial Pole "LD" Drum**. This high performance design offers a uniform, magnetic field across the full working width of the drum for maximum efficiency, less cylinder wear and less down time. Opposing north and south poles create a vigorous agitation for superior liberation of non-ferrous waste and a clean, less contaminated product that provides you additional value.



ELECTROMAGNETIC DRUMS LD-RADIAL DESIGN

DIMENSION "X" TO BE DEFINED ON CUSTOMER APPROVAL DRAWING

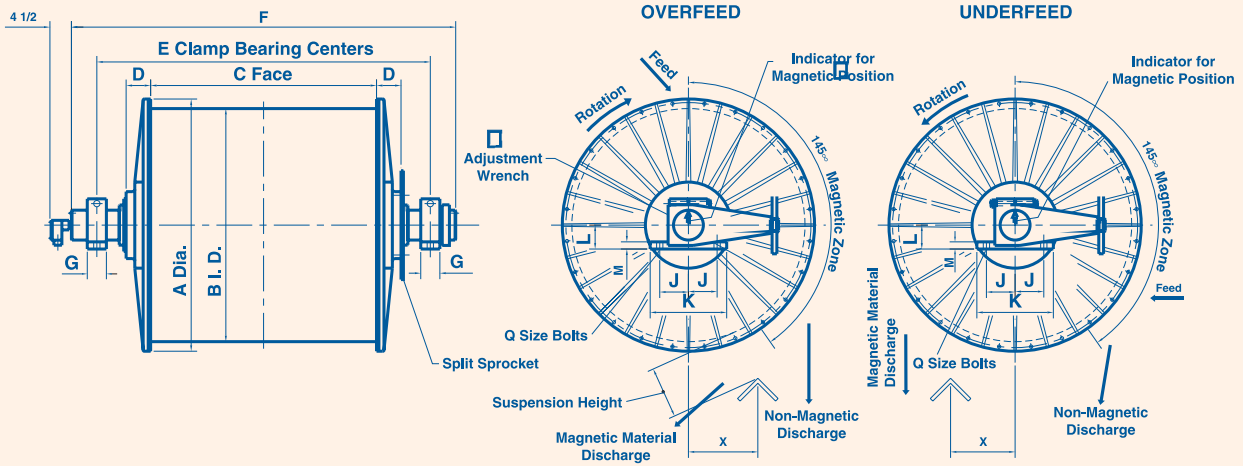

TECHNICAL SPECIFICATIONS AND DIMENSIONS (INCHES)

SIZE	WATTS	SHIP. WT. (lbs.)	DIMENSIONS (INCHES)											DRUM SPEED (RPM)	
			A	B	C	E	F	G	J	K	L	M	Q	FEED	
														UNDER	OVER
3036	1800	4400	33	30	35-1/4	54-3/4	66-3/4	3-1/2	4-1/2	11	3-1/2	1-1/4	3/4	35	30
3048	1825	5000	33	30	47-1/4	66-3/4	78-3/4	3-1/2	4-1/2	11	3-1/2	1-1/4	3/4	35	30
3060	2970	7100	33	30	59-1/4	78-3/4	90-3/4	3-1/2	4-1/2	11	3-1/2	1-1/4	3/4	35	30
3636	3200	4000	41-1/2	36	35-1/2	52-1/2	61-1/2	3-1/2	5-1/2	15	4-1/2	1-1/4	1	35	25
3642	3400	4520	41-1/2	36	41-1/2	58-1/2	67-1/2	3-1/2	5-1/2	15	4-1/2	1-1/4	1	35	25
3648	3800	5200	41-1/2	36	47-1/2	64-1/2	73-1/2	3-1/2	5-1/2	15	4-1/2	1-1/4	1	35	25
3654	4100	5800	41-1/2	36	53-1/2	70-1/2	79-1/2	3-1/2	5-1/2	15	4-1/2	1-1/4	1	35	25
3660	4400	6300	41-1/2	36	59-1/2	76-1/2	85-1/2	3-1/2	5-1/2	15	4-1/2	1-1/4	1	35	25
3672	5200	7600	41-1/2	36	71-1/2	88-1/2	97-1/2	3-1/2	5-1/2	15	4-1/2	1-1/4	1	35	25
4248	4600	6600	46-3/4	42	47-1/2	69-1/2	80	4	6	16	5	1-1/2	1-1/4	35	25
4254	5000	7300	46-3/4	42	53-1/2	75-1/2	86	4	6	16	5	1-1/2	1-1/4	35	25
4260	5400	8200	46-3/4	42	59-1/2	81-1/2	92	4	6	16	5	1-1/2	1-1/4	35	25
4272	6400	10,000	46-3/4	42	71-1/2	93-1/2	104	4	6	16	5	1-1/2	1-1/4	35	25
4848	5500	9300	52-3/4	48	47-1/2	69-1/2	80	4	6	16	5	1-1/2	1-1/4	30	23
4854	5800	9200	52-3/4	48	53-1/2	75-1/2	86	4	6	16	5	1-1/2	1-1/4	30	23
4860	6300	10,500	52-3/4	48	59-1/2	81-1/2	92	4	6	16	5	1-1/2	1-1/4	30	23
4872	7300	13,000	52-3/4	48	71-1/2	93-1/2	104	4	6	16	5	1-1/2	1-1/4	30	23
4884	7500	14,000	52-3/4	48	84	106	116	4	6	16	5	1-1/2	1-1/4	30	23
4896	9100	15,000	52-3/4	48	96	118	128	4	6	16	5	1-1/2	1-1/4	30	23
5454	6900	10,500	58-3/4	54	53-1/2	75-1/2	86	4	7-1/2	19	6	2	1-1/4	30	22
5460	7400	11,500	58-3/4	54	59-1/2	81-1/2	92	4	7-1/2	19	6	2	1-1/4	30	22
5472	8500	16,500	58-3/4	54	71-1/2	93-1/2	104	4	7-1/2	19	6	2	1-1/4	30	22
5484	8200	17,000	58-3/4	54	83-1/2	104	117	4	7-1/2	19	6	2	1-1/4	30	22
5496	8200	17,700	58-3/4	54	95-1/2	116	129	4	7-1/2	19	6	2	1-1/4	30	22
6060	8700	18,000	64-3/4	60	59-1/2	81-1/2	92	4	7-1/2	19	6	2	1-1/4	30	21
6072	9500	19,600	64-3/4	60	71-1/2	93-1/2	104	4	7-1/2	19	6	2	1-1/4	30	21
6084	9700	25,000	64-3/4	60	83-1/2	104	116	4	7-1/2	19	6	2	1-1/4	30	21

ELECTROMAGNETIC DRUMS LDA-AXIAL DESIGN
 DIMENSION "X" TO BE DEFINED ON CUSTOMER APPROVAL DRAWING

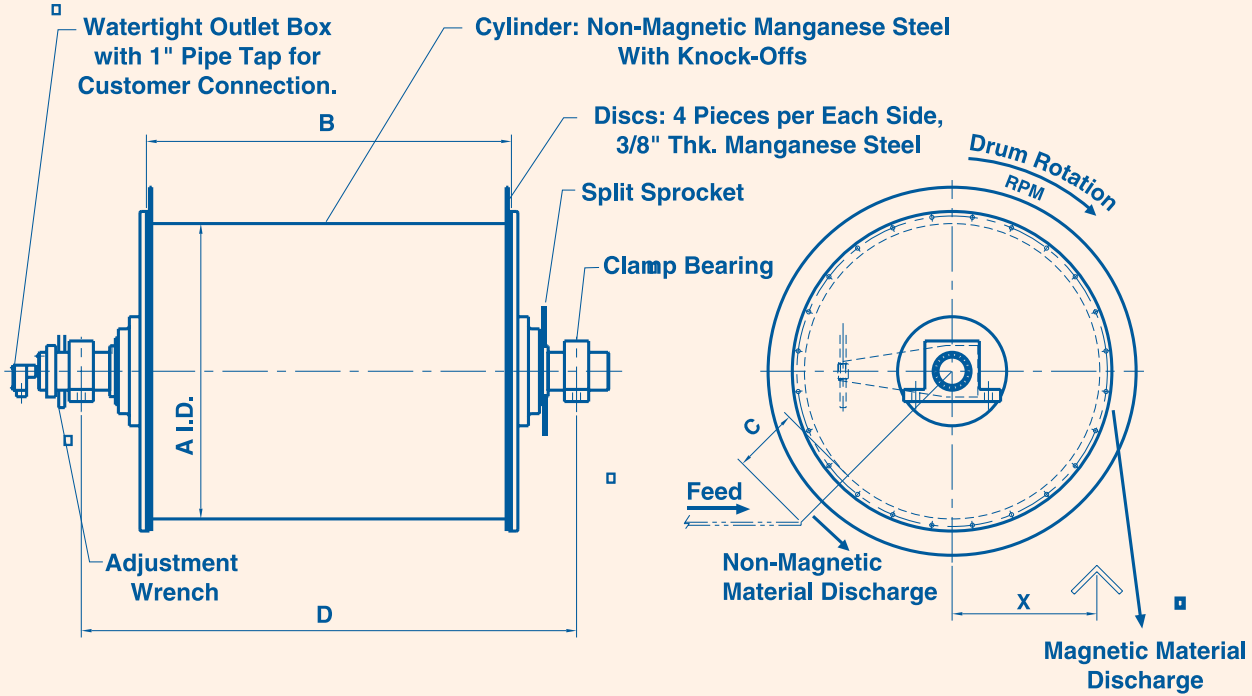

TECHNICAL SPECIFICATIONS AND DIMENSIONS (INCHES)

SIZE	WATTS		SHIP. WT. (lbs.)		DIMENSIONS (INCHES)				DRUM SPEED (RPM)
	STANDARD	SUPER	STANDARD	SUPER	A	B	C	D	
4860	6,200	6,200	10,000	10,500	48	60	9-10	82	20-25
4872	8,200	8,550	12,000	13,800	48	72	9-10	93-1/4	20-25
4884	10,000	10,300	13,700	16,000	48	84	9-10	105-1/4	20-25
4896	12,500	12,500	15,200	17,200	48	96	9-10	115-1/4	20-25
5472	10,500	10,450	14,000	19,500	54	72	10-11	93-1/4	20
5484	11,500	10,100	16,000	21,500	54	84	10-11	105-1/4	20
5496	12,500	12,500	18,000	18,000	54	96	10-11	115-1/4	20
6060	9,200	9,200	13,500	15,500	60	60	10-12	80	17-20
6072	12,500	11,500	16,000	22,000	60	72	10-12	93-1/4	17-20
6084	13,500	12,450	18,500	24,300	60	84	10-12	105-1/4	17-20
6096	14,000	13,400	22,000	26,600	60	96	10-12	115-1/4	17-20
7296		18,000		33,000	72	96	14	115-1/4	17
72110		20,000		37,000	72	110	14	130	17