



## **SECTION 5**

# **DC GENERATOR INFORMATION**

**OHIO MAGNETICS, INC.**

**A SUBSIDIARY OF PEERLESS-WINSMITH, INC**

**5400 DUNHAM ROAD  
MAPLE HTS., OHIO 44137-3687**

**PHONE: (800) 486-6446**

**MAIN FAX: (216) 662-2911**

**ENGINEERING FAX: (216) 662-3118**

**E-MAIL (SALES): sales@ohiomagnetics.com**

**E-MAIL (ENGINEERING): engineering@ohiomagnetics.com**

**INTERNET: <http://www.ohiomagnetics.com>**

OHIO  
DC GENERATORS  
FOR  
MAGNET SERVICE

GENERAL:

A DC generator is an electromechanical device designed to convert mechanical energy into DC electrical energy. It is available as a separate rotating device to be driven by an auxiliary shaft of the main engine of portable cranes. It is also available as a package unit complete with a gasoline or diesel engine.

Belt driven power takeoff generators must be operated at their rated speed in order to develop full rated voltage and power. For optimum performance the speed must be maintained within  $\pm 50$  r/min.

The generators are compound field wound units which are self regulating between zero and full load. The standard magnet generator is 230 V dc and is available in increments from 5 to 33 kW. This standard speed is 1800 r/min or the PTO units except the light weight 5, 8, and 10 kW units which are rated at 2500 r/min.

These generators are designed with extra thermal capacity to be able to withstand electromagnet service with ample safety factor. They are also mechanically rugged to resist shock and vibration present on portable cranes.

INSTALLATION OF P.T.O. UNITS:

Correct installation of the generator is essential to the proper operation and normal life expectancy of the unit. The following procedures and requirements should be observed:

1. Generator Speed:

Pulley diameters between input and output must be correct in order to obtain rated generator speed when the engine is at normal running speed. Under no conditions should the generator run above 20 % over speed.

Proper size and number of pulleys must be correct to drive the generator without slipping. Use pulleys for "C" size V-belts. Select the quantity of belts as follows:

<u>POWER (kW)</u>	<u>NO. OF BELTS</u>
5-7	1
8-13	2
14-32	3
33	4

Belt tension must be correct to prevent belt slippage. Excessive tension is not desirable and will result in high belt wear and possible bearing overload.

2. Alignment:

Mount the generator on a flat surface whose plane is parallel to the axis of the drive shaft.

Position the generator such that the two pulleys are in correct alignment for ideal belt tracking.

3. Direction of Rotation:

The generator is fixed to rotate in one direction only. Normally it is shipped to rotate clockwise when viewed from the shaft end. It can be modified to rotate counterclockwise in the field. See instructions below.

4. Unobstructed Air Flow:

Air circulation throughout the generator is required for proper cooling. No obstructions should be placed on either end of the generator that would obstruct the air flow.

**ADJUSTMENTS FOR DIRECTION OF ROTATION:**  
(Excluding the 5 kW generator)

The generator is normally shipped for clockwise rotation. This is the direction the belts will rotate the generator shaft when viewed from the shaft end.

To check or change the adjustments, the two covers on the commutator end must be removed.

The following information is submitted should it be necessary to change the generator rotation.

If there is only a single position mark on the brush holder ring then the brush does not have to be shifted. If there are marks, proceed as described below: (Note: The brush holder ring may have to be rotated to see the second mark.)

#### TO CHANGE TO CLOCKWISE

The red mark on the brush holder ring will be in line with the edge of the aluminum housing.

Position the black mark in line with the edge of the housing, loosen the hex head screws (do not remove) holding the brush holder ring to the housing. Rotate the brush ring until the blue mark is in line with the edge of the aluminum housing. Retighten the hex head screws.

The armature and inter pole connections must be reversed in the generator junction box by connecting A2 and S2 together. Re-insulate these connections. Wires A1, S1, and F1 are to be connected to wires going to the meter rheostat box. Wires A1 and S1 are to be sized for the current rating of the generator and F1 to be #12 - 4 mm<sup>2</sup> wire. See the connection diagram page.

#### TO CHANGE TO COUNTERCLOCKWISE:

The blue mark on the brush holder ring will be in line with the edge of the aluminum housing.

Position the red mark in line with edge of the housing, loosen the hex head screws (do not remove) holding the brush holder ring to the housing. Rotate the brush ring until the red mark is in line with the edge of the aluminum housing. Retighten the hex head screws.

The armature and inter pole field connections must be reversed in the generator junction box by connecting A1 and S2 together. Re-insulate these connections. Wires A2, S1, and F1 are to be connected to the wires going to the meter-rheostat box. Wires A2 and S1 are to be sized for the current rating of the generator and F1 to be #12- 4 mm<sup>2</sup> wire. See connection diagram attached.

GENERATOR CONNECTION DIAGRAM  
8 kW THRU 33 kW

CLOCKWISE ROTATION FACING SHAFT END

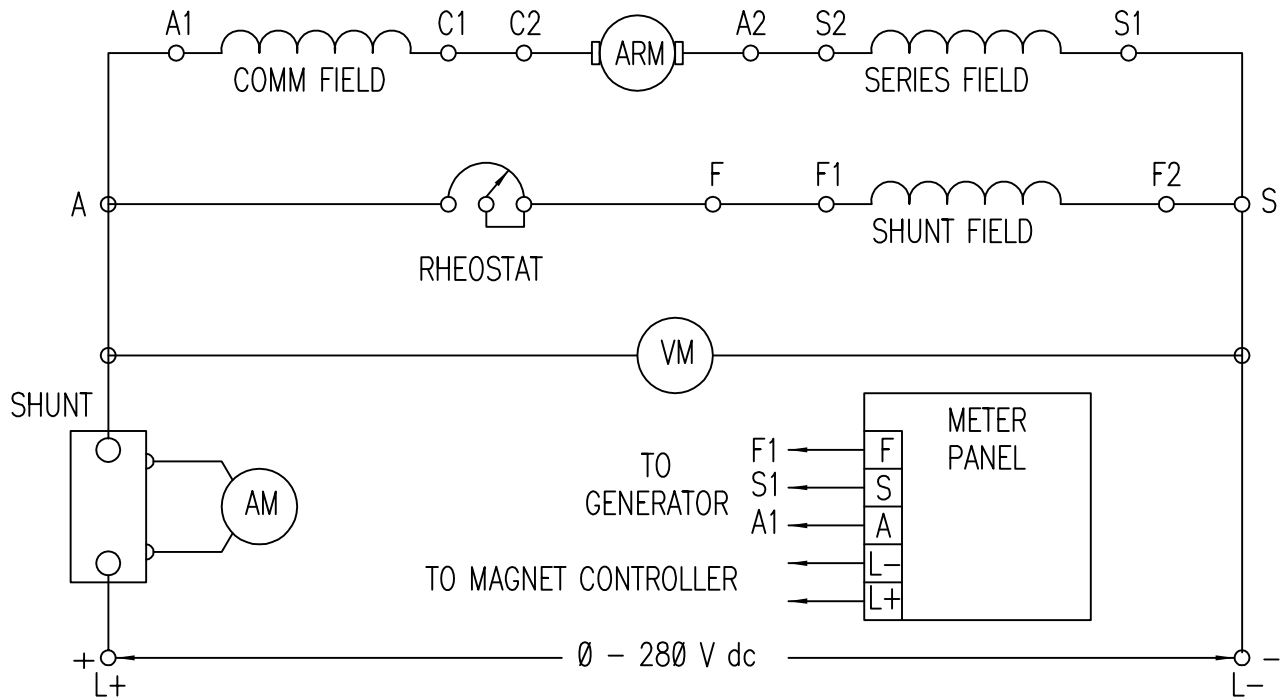

COUNTERCLOCKWISE ROTATION FACING SHAFT END

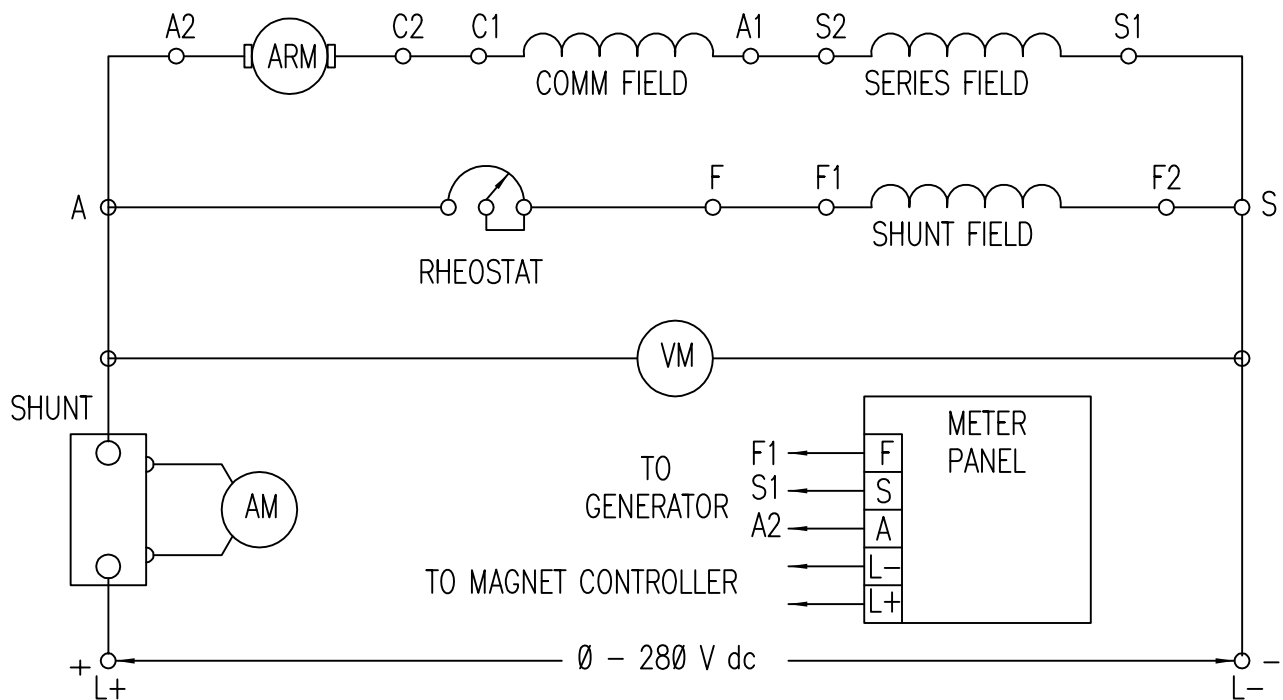

GENERATOR CONNECTION DIAGRAM  
5 kW

CLOCKWISE ROTATION FACING SHAFT END

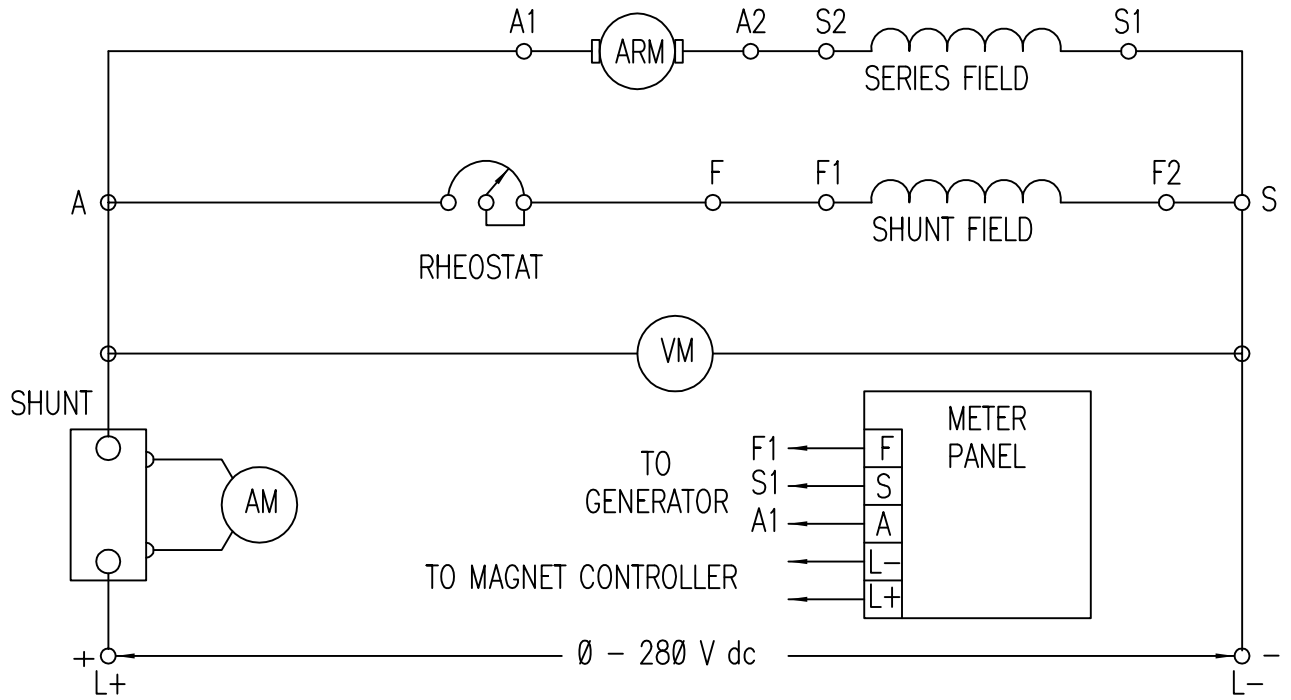

CLOCKWISE ROTATION FACING SHAFT END

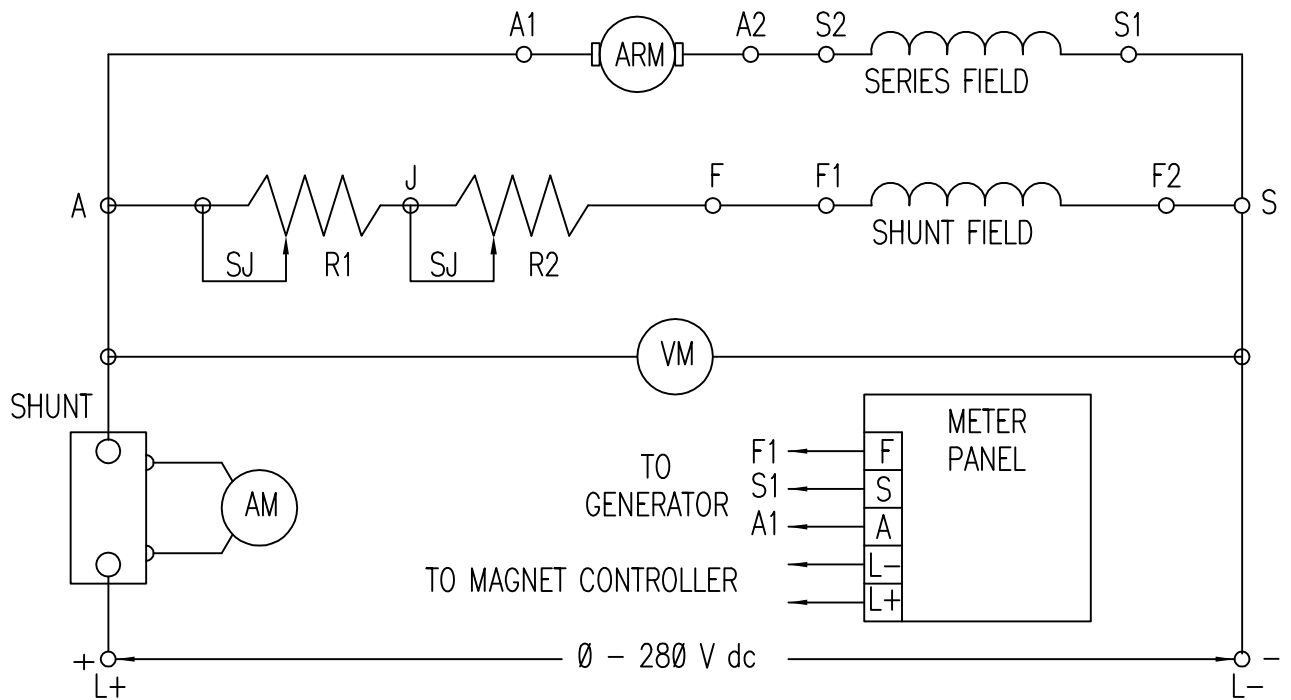

GENERATOR CONNECTION DIAGRAM  
8 kW THRU 33 kW

CLOCKWISE ROTATION FACING SHAFT END

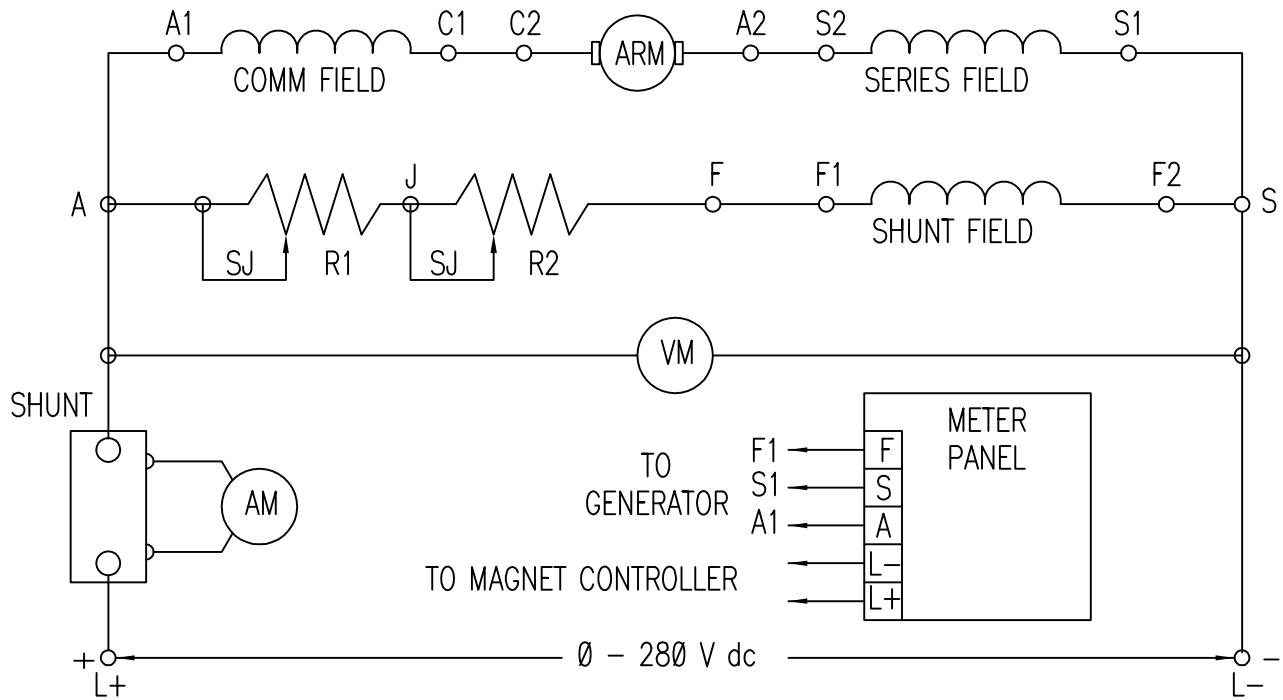

COUNTERCLOCKWISE ROTATION FACING SHAFT END

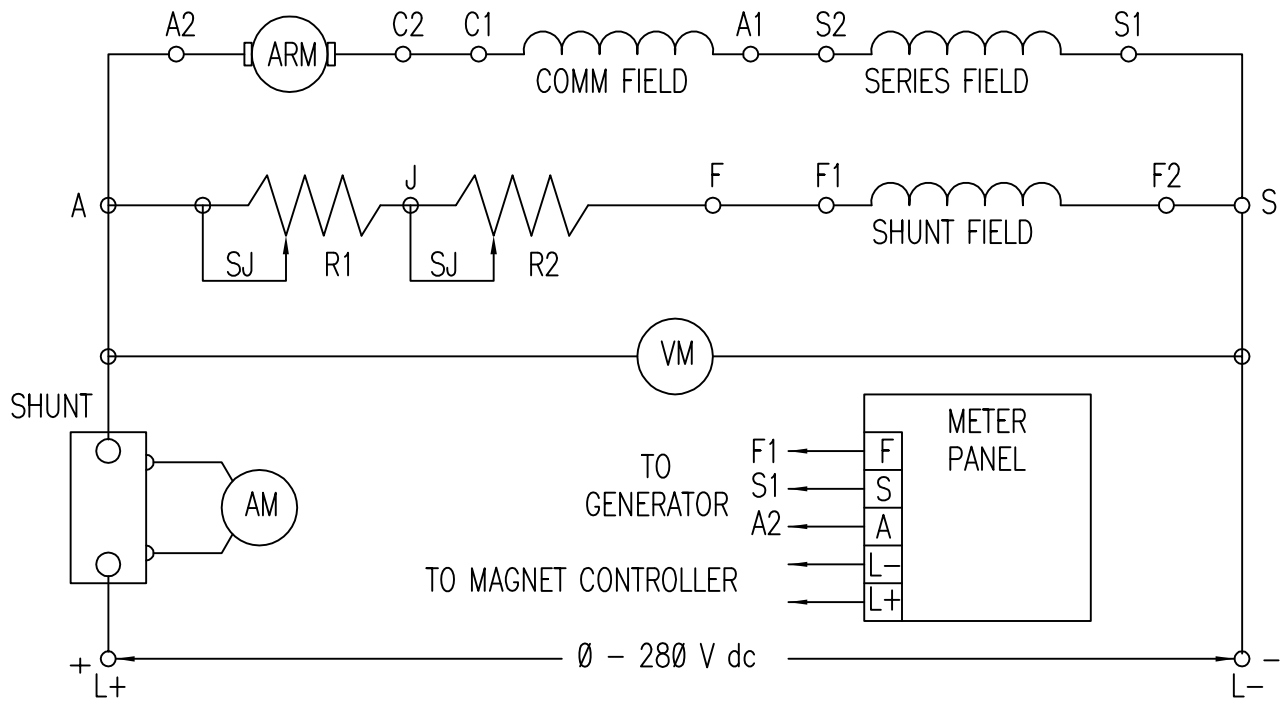

## MAINTENANCE:

Periodic inspection and maintenance should be performed to prevent failure and downtime. The following items should be checked.

1. BELTS:
  1. Check tension and belt condition.
  2. Worn or frayed belts should be replaced.
  
2. BRUSHES & COMMUTATOR:
  1. Worn or dirty commutator should be cleaned and dressed with a commutator stone.
  2. Undercut the mica if it extends above the bars.
  3. Replace worn brushes.
  
3. BEARINGS:
  1. Noisy or loose bearings should be replaced.
  2. Greasing bearings is not required as they are sealed and lubricated for life.

## TROUBLE SHOOTING:

### Problem

### Solution

Overheating:

- A. Over load magnet too large for generator.
- B. Shorted magnet or system.
- C. Obstruction at the cooling vents.
- D. Over speed of under speed.

No Voltage:

- A. Open armature or field.
- B. Worn brushes and/or brush spring broken.
- C. Open rheostat.
- D. Defective Voltmeter.
- E. Loss of residual magnetism. Flash generator with 12 V battery and observe correct polarity.
- F. Clean and dress commutator.

Low Voltage:

- A. Adjust rheostat.
- B. Low speed improper pulley ratio or belts slipping.
- C. Excessive line loss wiring too small.

High Voltage:

- A. Adjust rheostat.
- B. High speed improper pulley ratio.

Fluctuating  
Voltage:

- A. Loose terminal connections.
- B. Speed changing.
  - 1. Slipping belts.
  - 2. Defective engine governor.

Sparking Brushes:

- A. Worn brushes.
- B. Worn commutator.
- C. Brushes out-of-position.

## FIELD FLASHING

Restoring residual magnetism to the correct polarity, field flashing may be necessary. Either a 12 V battery or a 50 V dc welder can be used for this purpose. Follow the connection diagram below. Do not permanently connect the power sources to the generators. Contact between the power source and the generator should only be momentary.

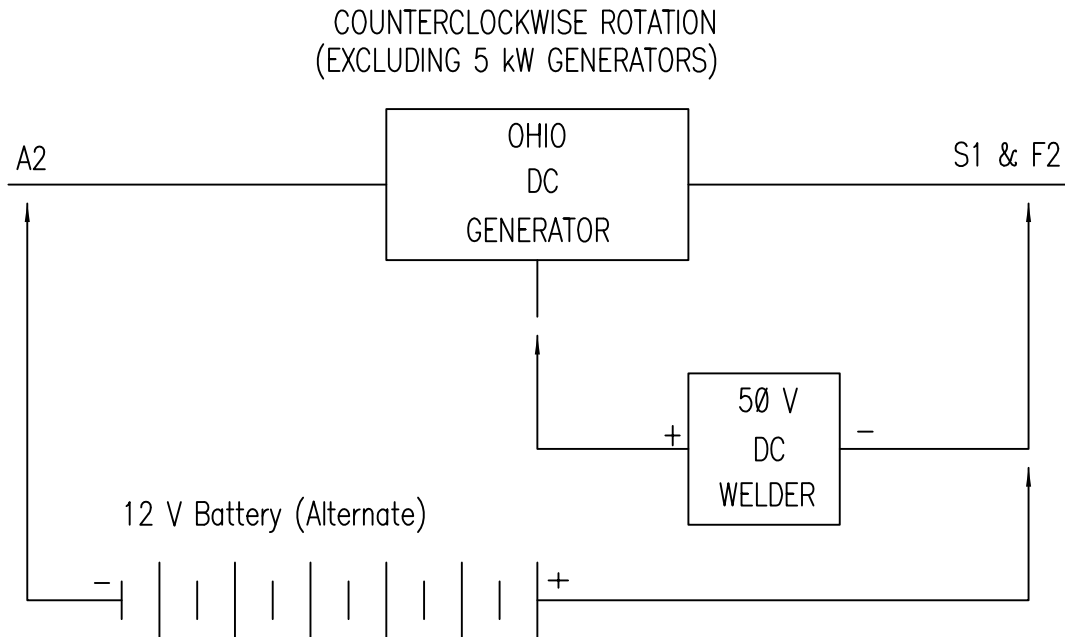
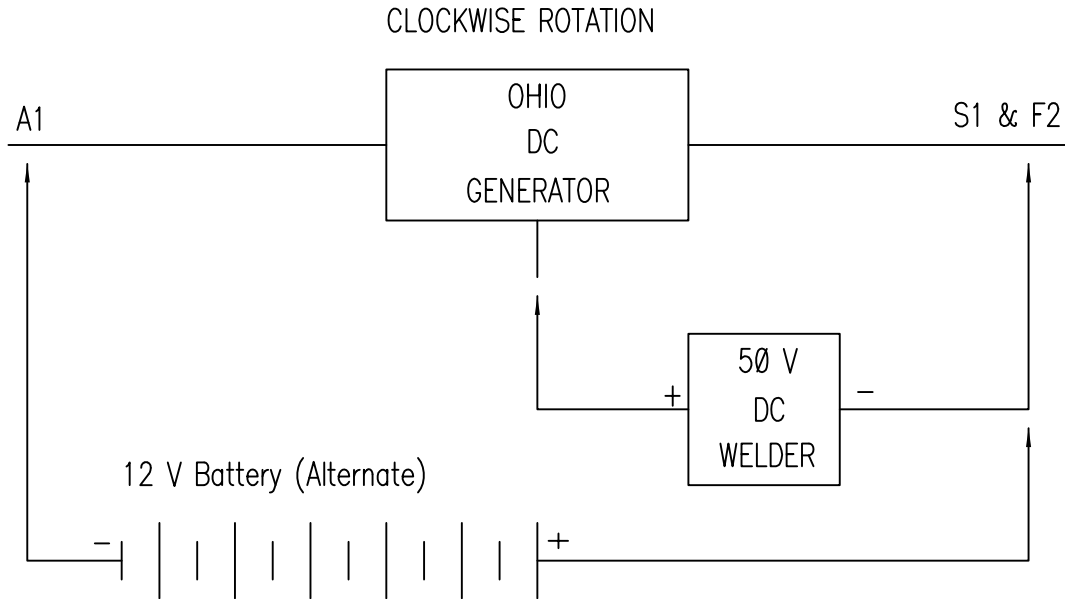

## INSTRUCTIONS FOR ENGINE GENERATOR SETS

Ohio Engine Generator Sets, both diesel and gasoline, use reliable engines which will give long service if the instructions for starting and operation and maintenance are followed. All engines are shipped with oil already in the crankcase and in the air cleaner unless the unit was shipped by air. The oil level should be checked to make sure it is proper.

The engine generator sets are run at the Ohio factory. It can be used directly on the job. The unit should, however, be checked for nameplate speed to prevent any over speed or under speed problems. Most engines use a variable speed governor. Do not touch this control. It has been preset at the factory. In no case should the generator speed exceed 2200 r/min for a rated 1800 r/min generator or 3000 r/min for a rated 2500 r/min.

Install the engine generator on a flat surface using the bolt holes provided for mounting. Do not twist the base when tightening down the unit. Use lock washers.

Run the engine generator set and make sure it does not vibrate excessively. If there is a vibration problem, reinforce the bolt down points if they are not rigid. If the vibration is being produced by other parts of the machine, isolate the engine generator from this vibration with isolation mounts.

Engine speed should be checked when other maintenance is done.

# SPARE PARTS LIST

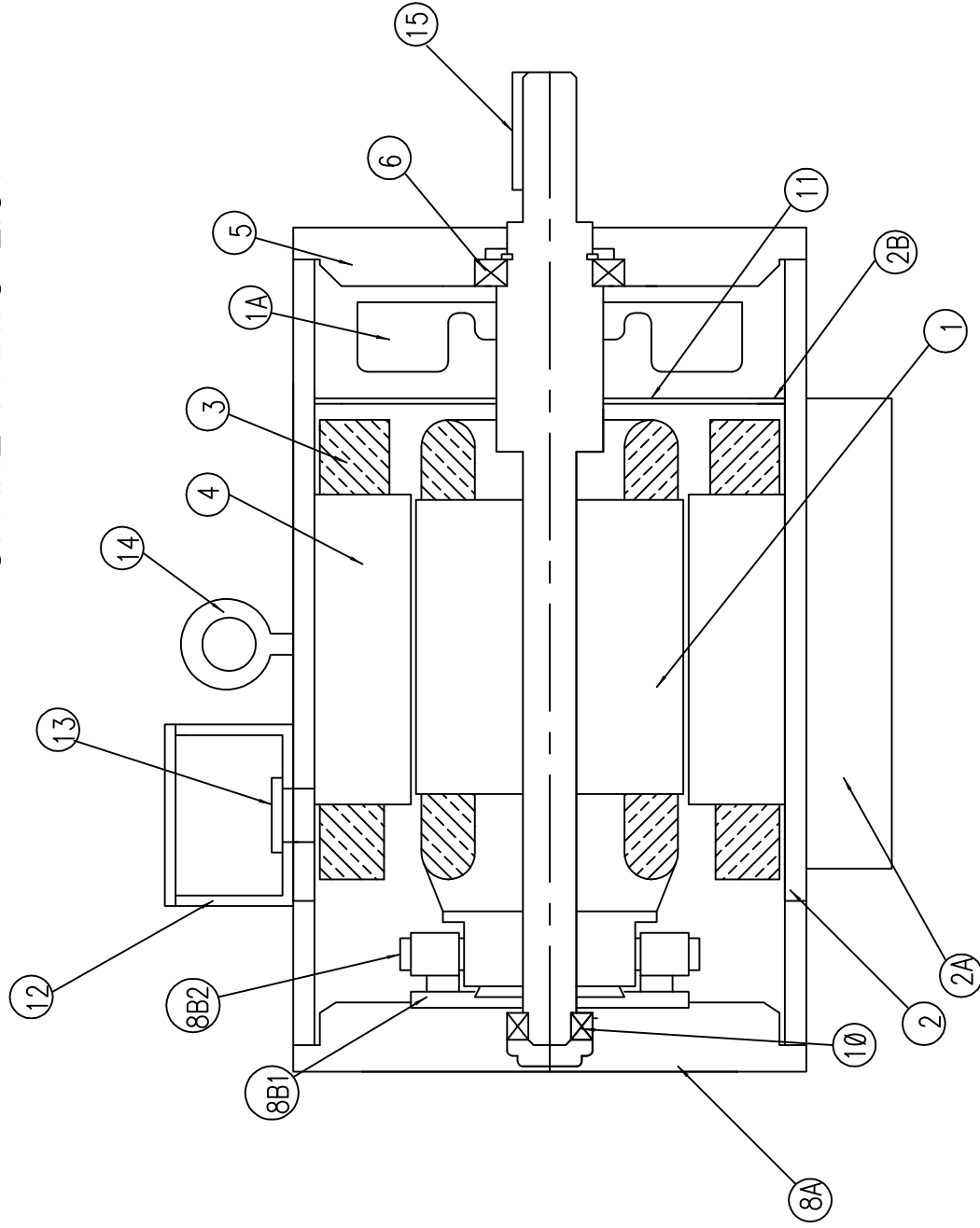

ITEM	QTY	PART NO.	DESCRIPTION
1	1	655024	CMPL ARMATURE ASSEMBLY
1A	1	307B016B1	FAN - DRILLED
2	1	307C015B1	STATOR RING & BASE ASSEMBLY
2A	2	307B015B3	BASE SECTION
2B	4	307A015A5	BAFFLE MTG BRACKETS
3	4	307B020A1	MAIN COILS
4	4	307B017A1	MAIN POLES
5	1	307C013A1	PULLEY COVER - DRILLED FOR OPT
5	1	307C013A4	PULLEY COVER - DRILLED FOR OPTH
6	1	A-900205-14	BEARING - PULLEY END
7	1	307C019A2	PULLEY COVER BAND
8A	1	307C014A1	COMM COVER - DRILLED
8B1	1	910B139A9	BRUSH RING ASSEMBLY
8B2	4	900B57B03	BRUSHES
8B3	4	910A139A14	BRUSH SPRINGS
9	1	307C019A5	COMM COVER BAND
10	1	A-900205-13	BEARING - COMM END
11	1	307B018B1	FAN BAFFLE
12	1	B-100235	TERMINAL BOX
13	1	A-900200-04	CHASE NIPPLE
14	1	A-900180-01	EYEBOLT
15	1	307A025A1	KEY

# SPARE PARTS LIST

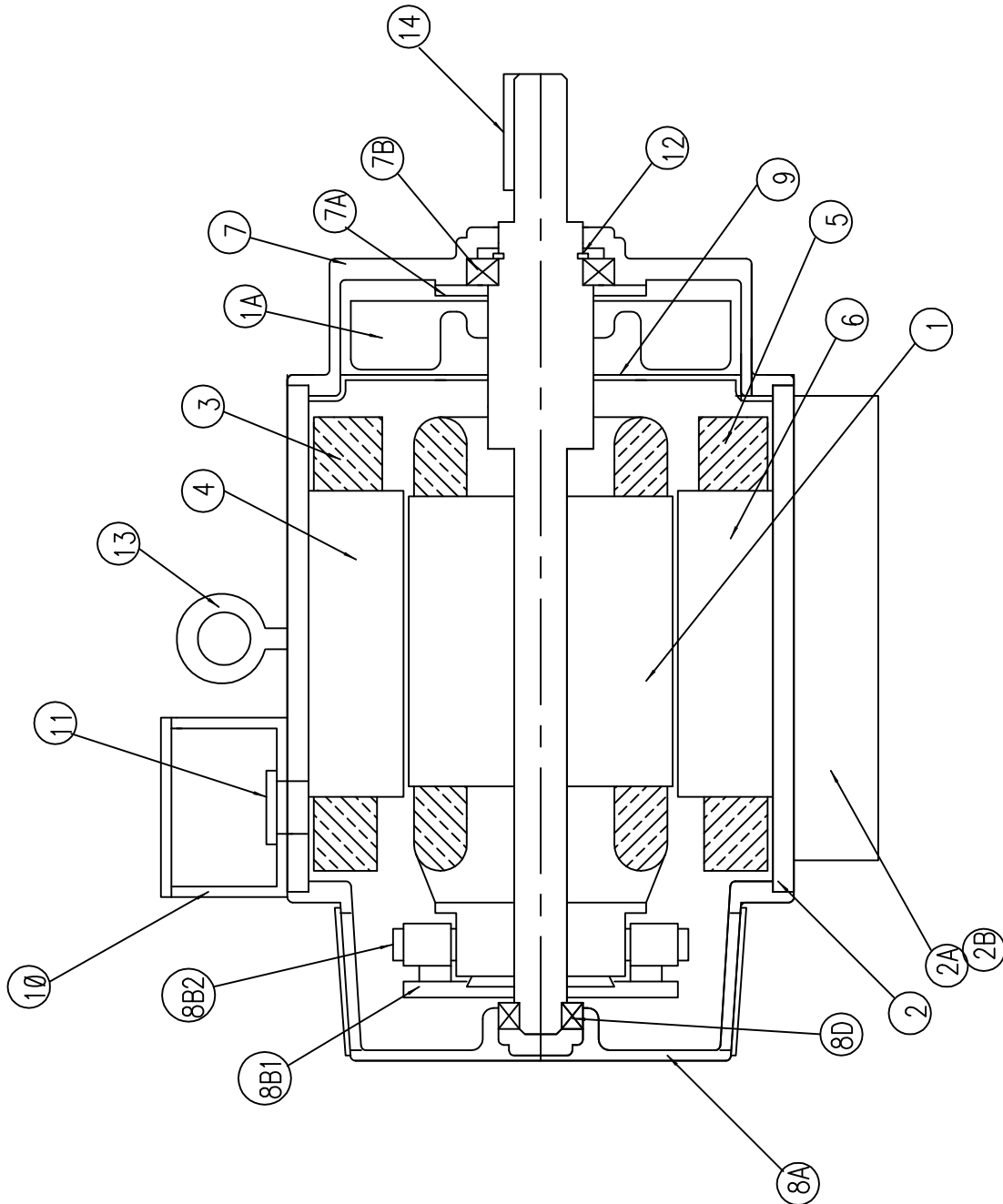

ITEM	QTY	PART NO.	DESCRIPTION
1	1	655002	CNPL ARMATURE ASSEMBLY
1A	1	B-230505-01	FAN - DRILLED
2	1	C-460101-03	STATOR RING & BASE ASSEMBLY
2A	2	A-100239-01	BASE SECTION
2B	1/1	A-690101/102	BASE SUPPORT
3	2	B-441201-03	COMM COILS
4	2	B-452001-03	COMM POLES
5	4	B-441001-03	MAIN COILS
6	4	B-451001-03	MAIN POLES
7	1	C-210522	PULLEY COVER - DRILLED FOR OPT
7A	1	C-210522-01	PULLEY COVER - DRILLED FOR OPTH
7B	1	B-230506-01	BEARING CAP - DRILLED
7C	1	A-900205-27	BEARING - PULLEY END
7D	2	A-100243-02	PULLEY COVER SCREEN
8A	1	C-220515	COMM COVER - DRILLED
8B1	1	910B139A2	BRUSH RING ASSEMBLY
8B2	4	900B57B01	BRUSHES
8B3	4	910A139A14	BRUSH SPRINGS
8C	1	A-100242-03	COMM COVER SCREEN
8D	1	A-900205-13	BEARING - COMM END
8E	2	910A121A1	BRUSH INSPECTION COVER GASKET
8F	2	A-100250	BRUSH INSPECTION COVER
9	2	310C025A1	FAN BAFFLE
10	1	B-100235	TERMINAL BOX
11	1	A-900200-04	CHASE NIPPLE
12	1	A-900220-01	BEARING RETAINING RING
13	1	A-900180-01	EYEBOLT
14	1	A-100022-11	KEY

# SPARE PARTS LIST

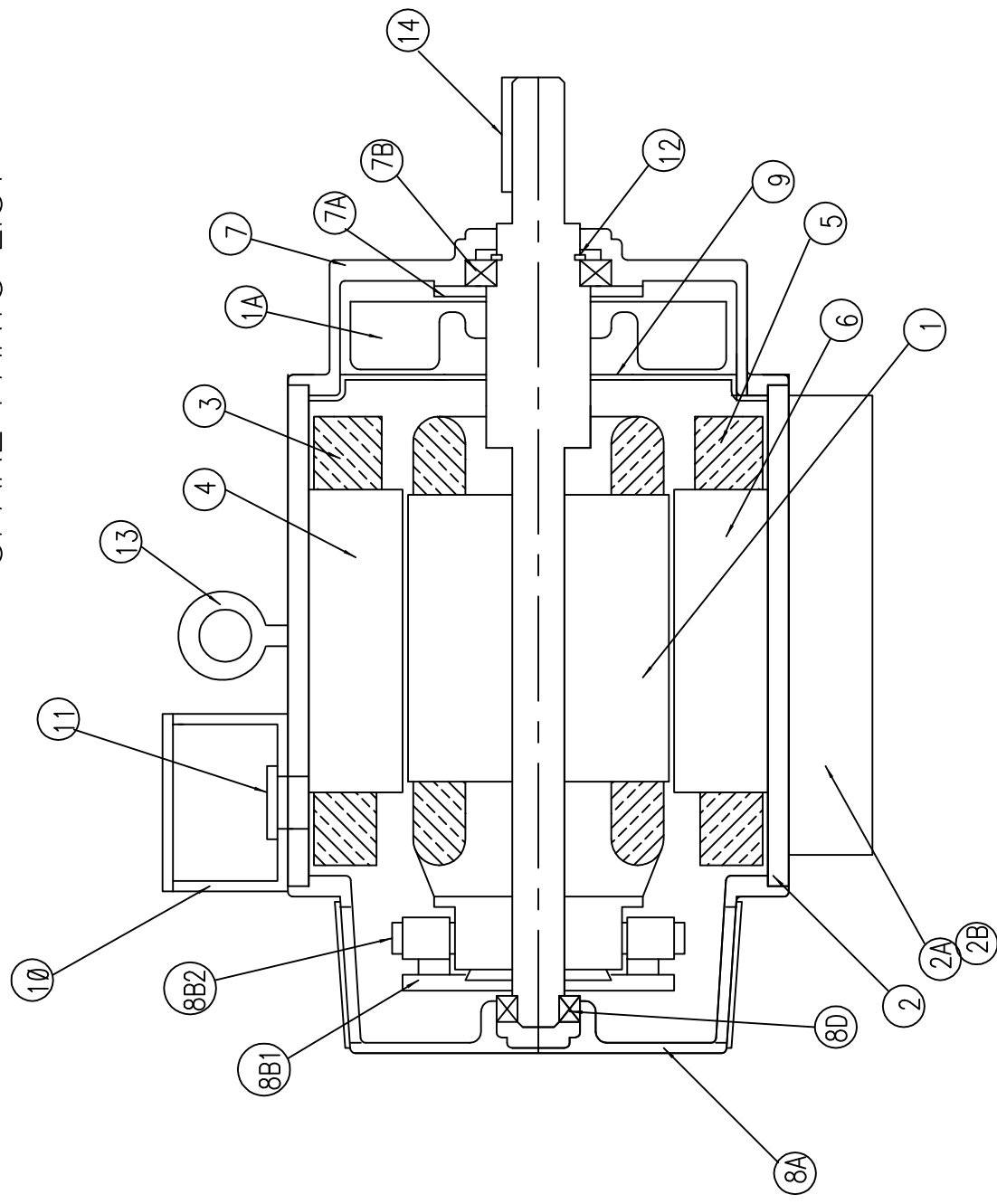

ITEM	QTY	PART NO.	DESCRIPTION
1	1	655012	CMPL ARMATURE ASSEMBLY
1A	1	B-230504-01	FAN - DRILLED
2	1	C-460100-03A	STATOR RING & BASE ASSEMBLY
2A	2	A-690100A	BASE SECTION
2B	2	A-100239-02	BASE SUPPORT
3	2	B-441200-04	COMM COILS
4	2	B-452000-04	COMM POLES
5	4	B-441000-04	MAIN COILS
6	4	B-451000-04	MAIN POLES
7	1	C-210520	PULLEY COVER - DRILLED FOR OPT
7A	1	N/A	PULLEY COVER - DRILLED FOR OPTH
7B	1	A-900205-28	BEARING CAP - DRILLED
7C	2	A-100243-01	BEARING - PULLEY END
7D	2	A-100243-01	BEARING - COMM END
8	1	C-220512	PULLEY COVER SCREEN
8A	1		COMM COVER - DRILLED
8B	1	910B137A2	BRUSH RING ASSEMBLY
8B2	4	900B57B02	BRUSHES
8B3	4	910A137A8	BRUSH SPRINGS
8C	1	A-100242-01	COMM COVER SCREEN
8D	1	A-900205-26	BEARING - COMM END
8E	2	910A121A3	BRUSH INSPECTION COVER GASKET
8F	2	A-100228	BRUSH INSPECTION COVER
9	2	311C025A1	FAN BAFFLE
10	1	B-100256	TERMINAL BOX
11	1	A-900200-03	CHASE NIPPLE
12	1	A-900220-02	BEARING RETAINING RING
13	1	A-900180-01	EYEBOLT
14	1	A-100022-08	KEY

# SPARE PARTS LIST

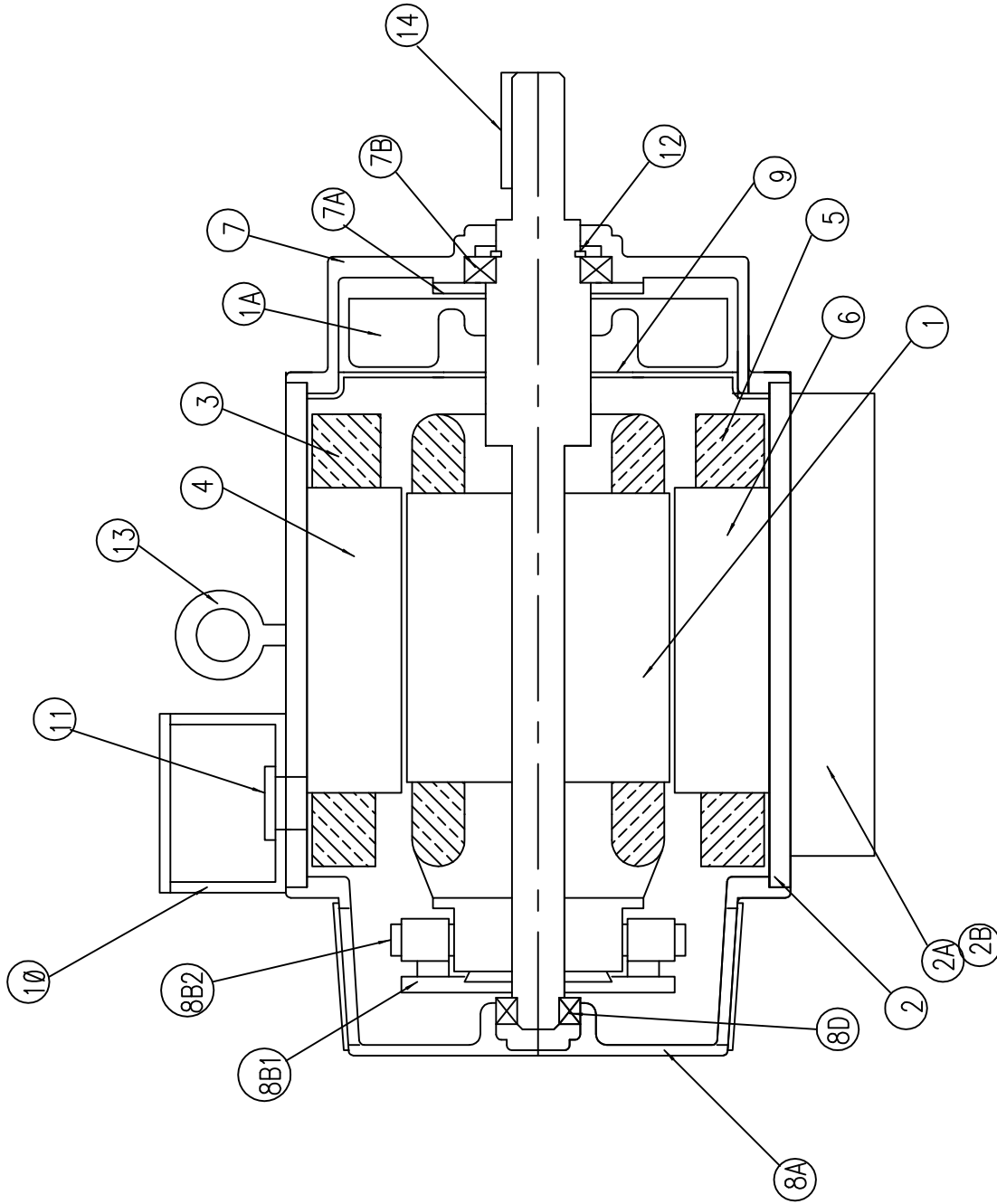

ITEM	QTY	PART NO.	DESCRIPTION
1	1	655015	CMPL ARMATURE ASSEMBLY
1A	1	B-230504-01	FAN - DRILLED
2	1	C-460100-02A	STATOR RING & BASE ASSEMBLY
2A	2	A-690100A	BASE SECTION
2B	2	A-100239-02	BASE SUPPORT
3	2	B-441200-03A	COMM COILS
4	2	B-452000-03	COMM POLES
5	4	B-441000-03B	MAIN COILS
6	4	B-451000-03	MAIN POLES
7	1	C-210520	PULLEY COVER - DRILLED
7A	1	C-210520-01	PULLEY COVER - DRILLED FOR OPT
7B	1	B-230506-02	BEARING CAP - DRILLED FOR OPT
7C	2	A-900205-28	BEARING - PULLEY END
7D	2	A-100243-01	PULLEY COVER SCREEN
8A	1	C-220512	COMM COVER - DRILLED
8B1	1	910B137A2	BRUSH RING ASSEMBLY
8B2	4	900B57B02	BRUSHES
8B3	4	910A137A8	BRUSH SPRINGS
8C	1	A-100242-01	COMM COVER SCREEN
8D	1	A-900205-26	BEARING - COMM END
8E	2	910A121A3	BRUSH INSPECTION COVER GASKET
8F	2	A-100228	BRUSH INSPECTION COVER
9	2	311C025A1	FAN BAFFLE
10	1	B-100256	TERMINAL BOX
11	1	A-900200-03	CHASE NIPPLE
12	1	A-900220-02	BEARING RETAINING RING
13	1	A-900180-01	EYEBOLT
14	1	A-100022-08	KEY

REV. 10-3-00

OPT-20-18-W1307 & OPTH-20-18-W1307

# SPARE PARTS LIST

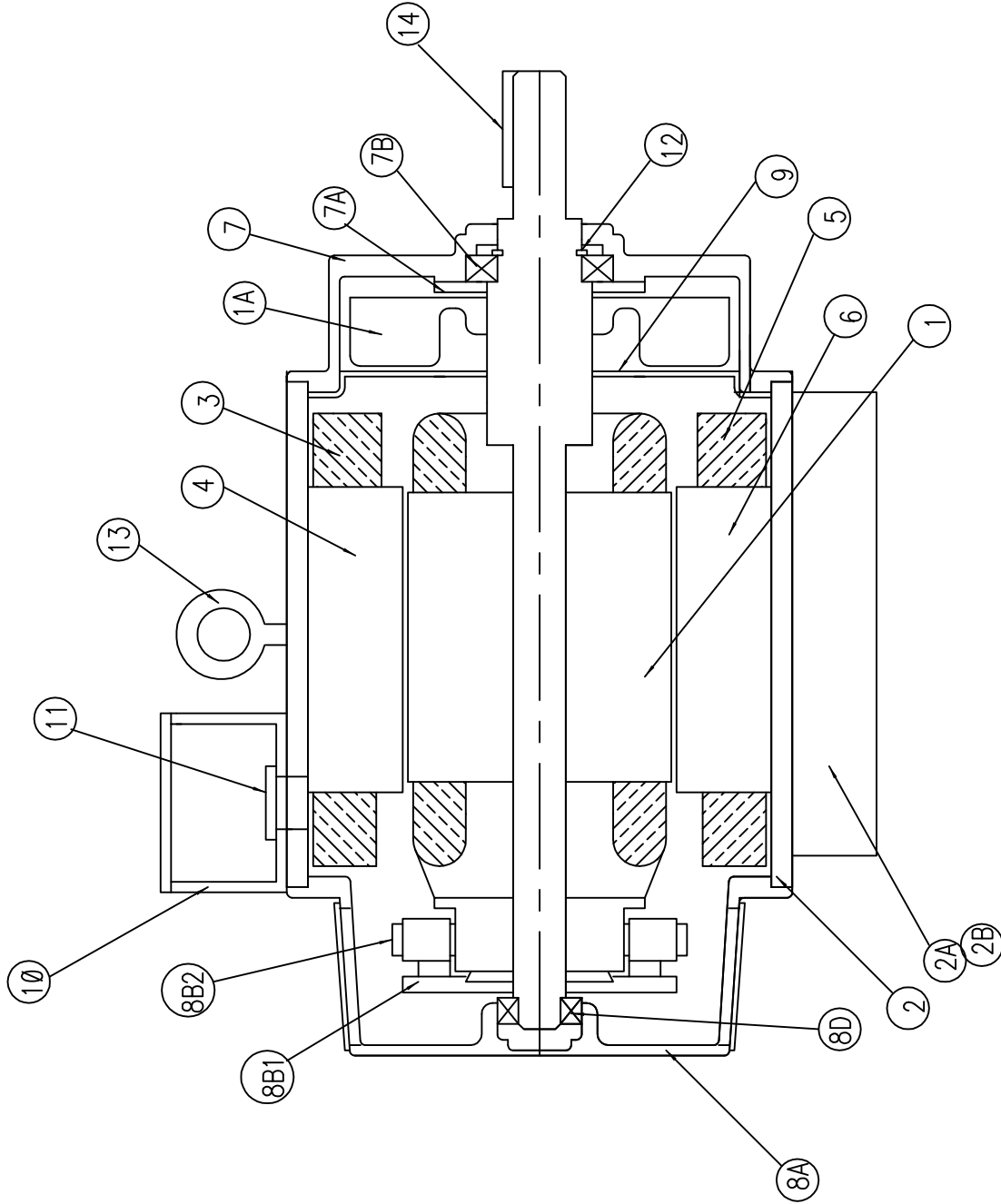

ITEM	QTY	PART NO.	DESCRIPTION
1	1	655019	CMPL ARMATURE ASSEMBLY
1A	1	B-230504-01	FAN - DRILLED
2	1	C-460100-01A	STATOR RING & BASE ASSEMBLY
2A	2	A-690100A	BASE SECTION
2B	2	A-100239-02	BASE SUPPORT
3	2	B-441200-01	COMM COILS
4	2	B-452000-01	COMM POLES
5	4	B-441000-01	MAIN COILS
6	4	B-451000-01	MAIN POLES
7	1	C-210520	PULLEY COVER - DRILLED FOR OPT
7A	1	N/A	PULLEY COVER - DRILLED FOR OPTH
7B	1	A-900205-28	BEARING CAP - DRILLED
7C	2	A-100243-01	BEARING - PULLEY END
8A	1	C-220512	PULLEY COVER SCREEN
			COMM COVER - DRILLED
8B1	1	910B137A2	BRUSH RING ASSEMBLY
8B2	4	900B57B02	BRUSHES
8B3	4	910A137A8	BRUSH SPRINGS
8C	1	A-100242-01	COMM COVER SCREEN
8D	1	A-900205-26	BEARING - COMM END
8E	2	910A121A3	BRUSH INSPECTION COVER GASKET
8F	2	A-100228	BRUSH INSPECTION COVER
9	2	311C025A1	FAN BAFFLE
10	1	B-100256	TERMINAL BOX
11	1	A-900200-03	CHASE NIPPLE
12	1	A-900220-02	BEARING RETAINING RING
13	1	A-900180-01	EYEBOLT
14	1	A-100022-08	KEY

REV. 10-3-00

OPT-25-18-WI308 & OPTH-25-18-WI308

# SPARE PARTS LIST

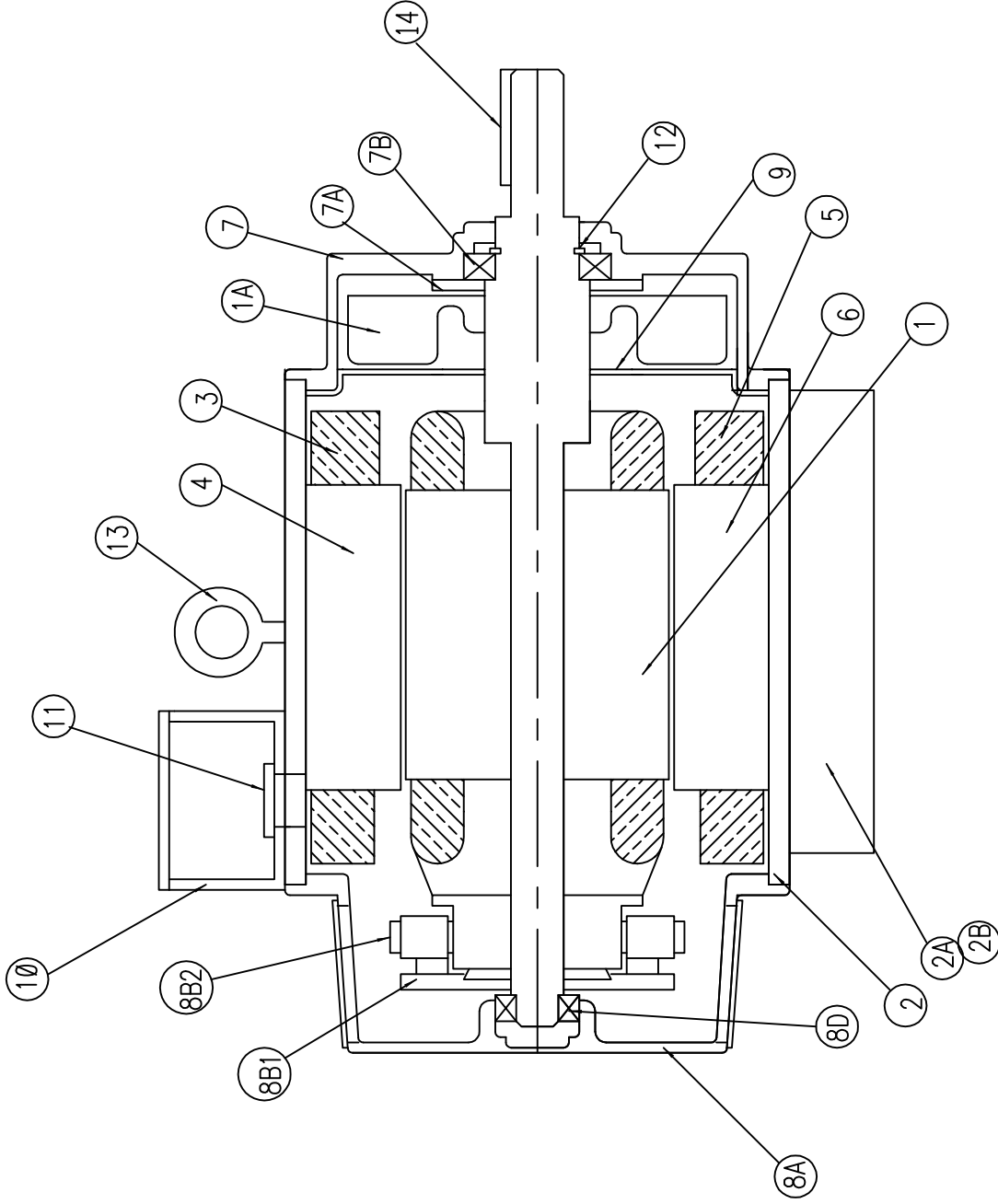

ITEM	QTY	PART NO.	DESCRIPTION
1	1	655022	CMPL ARMATURE ASSEMBLY
1A	1	B-230508-01	FAN - DRILLED
2	1	C-460106	STATOR RING & BASE ASSEMBLY
2A	2	A-690109	BASE SECTION
2B	2	A-100239-03	BASE SUPPORT
3	2	B-441203-01	COMM COILS
4	2	B-452004-01	COMM POLES
5	4	B-441002-01	MAIN COILS
6	4	B-451002-01	MAIN POLES
7	1	C-210531	PULLEY COVER - DRILLED FOR OPT
7A	1	B-230509	PULLEY COVER - DRILLED FOR OPT
7B	1	A-900205-33	BEARING CAP - DRILLED
7C	2	A-100243-05	BEARING - PULLEY END
8A	1	C-220516	PULLEY COVER SCREEN
			COMM COVER - DRILLED
8B1	1	910C138A2	BRUSH RING ASSEMBLY
8B2	8	900B57B02	BRUSHES
8B3	8	910A137A8	BRUSH SPRINGS
8C	1	A-100265-01	COMM COVER SCREEN
8D	1	A-900205-32	BEARING - COMM END
8E	2	910A121A4	BRUSH INSPECTION COVER GASKET
8F	2	A-100262	BRUSH INSPECTION COVER
9	1	A-100260	FAN BAFFLE
10	1	B-100259	TERMINAL BOX
11	1	A-900200-03	CHASE NIPPLE
12	1	A-900220-05	BEARING RETAINING RING
13	1	A-900180-02	EYEBOLT
14	1	A-100022-09	KEY

## INSTRUCTIONS FOR REWORK OF 5 kW "CW" TO "CCW" GENERATOR

- 1.) Remove the key from the existing shaft extension.
- 2.) Remove the hole plug from the end cover opposite the existing shaft extension.
- 3.) Thread the new shaft extension in tapped hole provided in the armature shaft, using "lock-tite" on the threads (provided in your conversion kit) to make sure the shaft adaptor is securely attached.
- 4.) The key that was removed from the other shaft extension is to be used on the new extension.
- 5.) Remove the screws and lockwashers (on the  $\text{Ø}75$  mm (3.00") B.C.) on the pulley cover and assemble path shaft covers over the shaft. The lower one (lower by 1.5 mm (0.06")) is to be assembled first.

The Conversion Kit Consists of: 307L02A01 Kit

- (1) Tube "Lock-tite" - 6 mL - A-950049-01
- (2) Shaft Covers - (1) 307A028A1 & (1) 307A028A2
- (1) Shaft Adapter - 307B021A2

## ADJUSTMENT PROCEDURE FOR GENERATOR SLIDE BAR RESISTORS

REFERENCE PANEL ASSEMBLY DIAGRAM: 101CO11A9 (50 A); 101CO11A8 (100 A); 101CO11A7 (150 A); 101CO11A6 (200 A)

REFERENCE METER PANEL WIRING DIAGRAM FOR OHIO GENERATORS: 101B002H15 (50 A); 101B002H13 (100 A); 101B002H14 (150 A); 101B002H10 (200 A); 101B002H21 (50 A); 101B002H20 (100 A); 101B002H17 (150 A); 101B002H25 (200 A)

REFERENCE METER PANEL WIRING DIAGRAM FOR ONAN GENERATORS: 101B002H22 (50 A); 101B002H26 (100 A); 101B002H27 (150 A); 101B002H28 (200 A)

### INSTRUCTIONS:

1.) Turn on the generator and measure the voltage. If the voltage is in the range of 230 to 250 V-dc, no adjustments need be made.

**Warning: ! DANGER OF ELECTROCUTION! Do not adjust the resistors with power on! Shut down the generator first. Also beware that resistors may be hot. Check for heat before touching resistors.**

1.) Loosen the slide contact on BOTH resistors. If the voltage is too high, slide the R1 (TOP RESISTOR) contact to the left and the R2 (BOTTOM RESISTOR) contact to the right. Move the contact no more than 10 mm at a time and equally on both resistors. If the voltage is too low, then move the contacts in the opposite direction stated above.

2.) Restart the generator and check the voltage again. If the voltage is within the proper limits, then no further adjustments need be made. If the voltage is still outside the limits, repeat step 1.

If over time, the voltage drifts out of range, repeat steps 1 and 2 to correct the error.